



28-pin SOIC



48-pin LQFP



100-pin LQFP

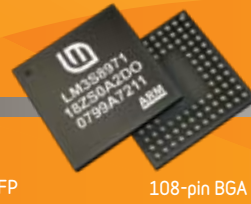

108-pin BGA



64-pin LQFP



# Luminary Micro Stellaris Family of Microcontrollers



Luminary Micro's Stellaris is the industry's leading family of robust, real-time microcontrollers (MCUs) based on the revolutionary Cortex™-M3 technology from ARM®. The award-winning Stellaris 32-bit MCUs combine sophisticated, flexible mixed-signal system-on-chip integration with unparalleled real-time multi-tasking capabilities. Complex applications previously impossible with legacy MCUs can now be accommodated with ease by powerful, cost-effective and simple-to-program Stellaris MCUs. With over 130 members in its family, the Stellaris family offers the widest selection of precisely-compatible MCUs in the industry.

The Stellaris family is positioned for cost-conscious applications requiring significant control processing and connectivity capabilities, including motion control, monitoring (remote, fire/ security, etc.), HVAC and building controls, power and energy monitoring and conversion, network appliances and switches, factory automation, electronic point-of-sale machines, test and measurement equipment, medical instrumentation, and gaming equipment.

In addition to MCUs configured for general-purpose real-time systems, the Stellaris family offers distinct solutions for advanced motion control and energy conversion applications, real-time networking and real-time internet networking, and combinations of these applications including connected motion control and hard real-time networking. Welcome to the future of microcontrollers!

## Why Choose the ARM Architecture?

For the first time ever, embedded microcontroller system designers can utilize 32-bit performance for the same price as their current 8- and 16-bit microcontroller designs!

- With entry-level pricing at \$1.00 for an ARM technology-based MCU, Luminary Micro's Stellaris product line allows for standardization that eliminates future architectural upgrades or software tools changes.
- With an ARM-based embedded market that is currently shipping at a rate of greater than 3.2 billion processors per year, the ARM ecosystem of third-party tools and solutions providers is the largest in the world.
- With the ARM Cortex architecture, designers have access to an instruction-set-compatible family that ranges from \$1 to 1 GHz.

## Why Choose Cortex-M3 from Luminary Micro?

**Cortex-M3 is the MCU version of ARM's V7 instruction set architecture family of cores:**

- Optimized for single-cycle flash usage
- Deterministic, fast interrupt processing: always 12 cycles, or just 6 cycles with tail-chaining
- Three sleep modes with clock gating for low power
- Single-cycle multiply instruction and hardware divide
- Atomic operations
- ARM Thumb2 mixed 16-/32-bit instruction set
- 1.25 DMIPS/MHz—better than ARM7 and ARM9
- Extra debug support including data watchpoints and flash patching

**Capabilities beyond ARM7 for the microcontroller market:**

- Requires approximately 1/2 the flash (code space) of ARM7 applications
- 2–4 times faster on MCU control applications
- No assembly code required—ever!

## Why Choose the Stellaris Family?

Designed for serious microcontroller applications, the Stellaris family provides the entry into the industry's strongest ecosystem, with code compatibility ranging from \$1 to 1 GHz.

- Superior integration saves up to \$3.28 in system cost
- Over 130 Stellaris family members to choose from
- Real MCU GPIOs—all can generate interrupts, are 5V-tolerant, and have programmable drive strength and slew rate control
- No functional pin muxing—choose your part by the functions you need
- Advanced communication capabilities, including 10/100 Ethernet MAC/PHY, USB and USB OTG, and CAN controllers
- Sophisticated motion control support in hardware and software
- Both analog comparators and ADC functionality provide on-chip system options to balance hardware and software performance
- Development is easy with the royalty-free Stellarisware software

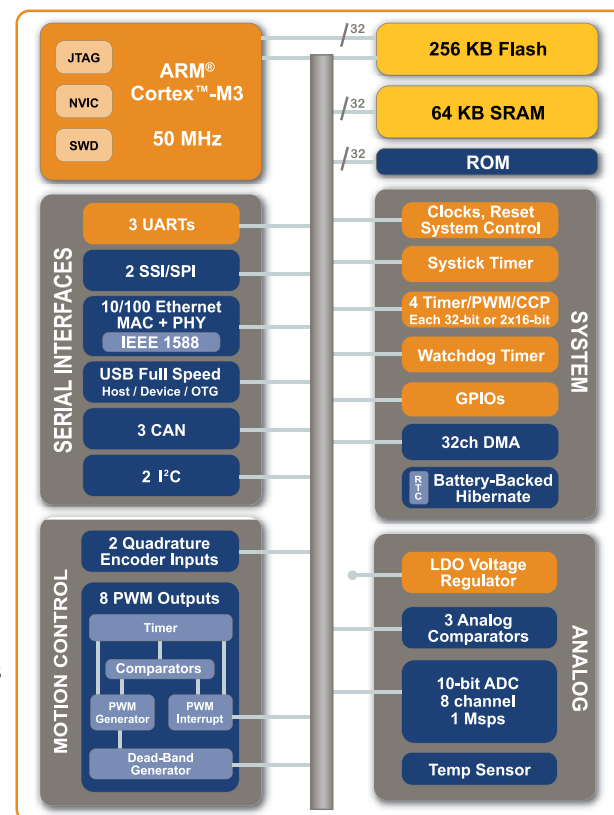

Stellaris Family Block Diagram



## Product Development

Luminary Micro provides a range of support designed to get your applications to market faster and easier than ever before. Compact, versatile, and connected! Luminary Micro evaluation kits provide a low-cost and effective means of evaluating our microcontrollers and getting a jump start on your design [www.luminarymicro.com/products/evaluation\\_kits.html/](http://www.luminarymicro.com/products/evaluation_kits.html/):



Stellaris LM3S811 Evaluation Kit



Stellaris LM3S1968 Evaluation Kit



Stellaris LM3S2965 Evaluation Kit



Stellaris LM3S3748 Evaluation Kit



Stellaris LM3S3768 Evaluation Kit



Stellaris LM3S6965 Evaluation Kit



Stellaris LM3S8962 Evaluation Kit

Our reference design kits accelerate product development by providing ready-to-run hardware, software, and comprehensive documentation including hardware design files [www.luminarymicro.com/products/reference\\_design\\_kits/](http://www.luminarymicro.com/products/reference_design_kits/):



Stellaris Intelligent Display Module Reference Design Kit



Intelligent Display Module with 3.5" Landscape Display Reference Design Kit



Stellaris Serial to Ethernet Reference Design Kit



Stellaris Stepper Motor Reference Design Kit



Stellaris Brushless Motor Reference Design Kit



Stellaris Brushed DC Motor Control with CAN Reference Design Kit



Stellaris AC Induction Motor Reference Design Kit

## Software made easy!

With Stellaris microcontrollers, all your programming can be in C/C++, even interrupt service routines and startup code. Luminary Micro makes it even easier by providing StellarisWare software support that includes code and royalty-free libraries for applications support. The Stellaris Peripheral Driver Library provides a royalty-free set of drivers for controlling the peripherals found on Stellaris MCUs, and can be used as applications examples or directly included in user applications as-is. The Stellaris USB Library is a set of data types and functions for creating USB device, host, or On-the-Go (OTG) applications for Stellaris microcontroller-based systems. Luminary Micro also provides a Stellaris Graphics Library that supports graphics primitives and a widget set for creating graphical user interfaces for Stellaris microcontroller-based systems that have a graphical display.

All Stellaris MCUs ship with a serial flash loader programmed into flash, providing maximum flexibility for production programming options. Luminary Micro also provides a royalty-free Stellaris boot loader that facilitates in-field updates for end applications, with flexible interface options and program signaling. In some Stellaris microcontrollers, the Stellaris boot loader is included in ROM.



## Flexibility in Production

Luminary Micro provides flexibility in go-to-market strategies for a range of applications areas. Engineers can start product evaluation and development with a Stellaris Evaluation Kit ([www.luminarymicro.com/products/evaluation\\_kits.html](http://www.luminarymicro.com/products/evaluation_kits.html)) or with a ready-to-run Stellaris Reference Design Kit ([www.luminarymicro.com/products/reference\\_design\\_kits.html](http://www.luminarymicro.com/products/reference_design_kits.html)). Engineers can then go directly into production using an off-the-shelf, ready-to-integrate Stellaris Module ([www.luminarymicro.com/products/modules.html](http://www.luminarymicro.com/products/modules.html)), or by integrating the open-tooled royalty-free reference design hardware and software into the embedded application system.

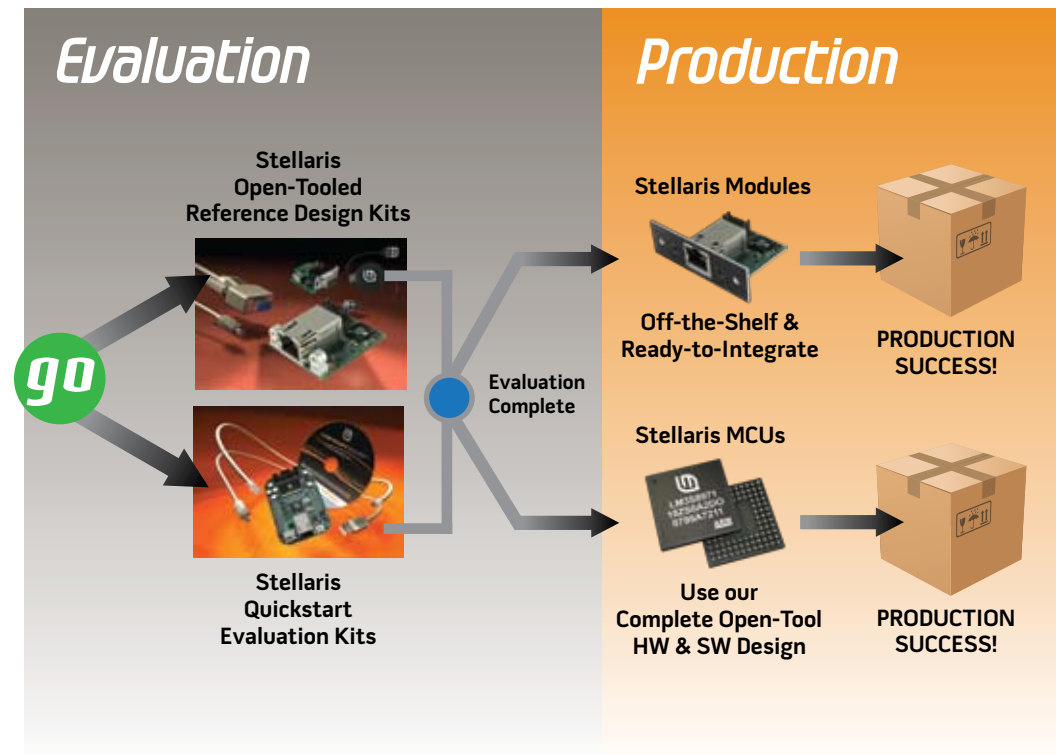

Luminary Micro modules accelerate time to market by providing ready-to-run hardware and useful software in a convenient module form-factor. With an open-tooled approach to reference design kits and modules, users can either obtain pre-built modules from Luminary Micro, or build the modules using their own board manufacturing facilities. The board development packages available for each module from <http://www.luminarymicro.com/products/modules.html> provide schematics, BOM, and Gerbers.



## Information you need—when you need it

Getting the technical information you need has never been easier! Luminary Micro provides registered web users with a very flexible means of defining the automatic engineering communications you would like to receive. Based on the user profile you define, Luminary Micro will provide automatic notification of software updates, datasheet updates, errata, and product change notices on a per-product or range-of-products basis. Simply register and log in to the Luminary Micro web site, and set up your communications requirements under "Email Preferences".

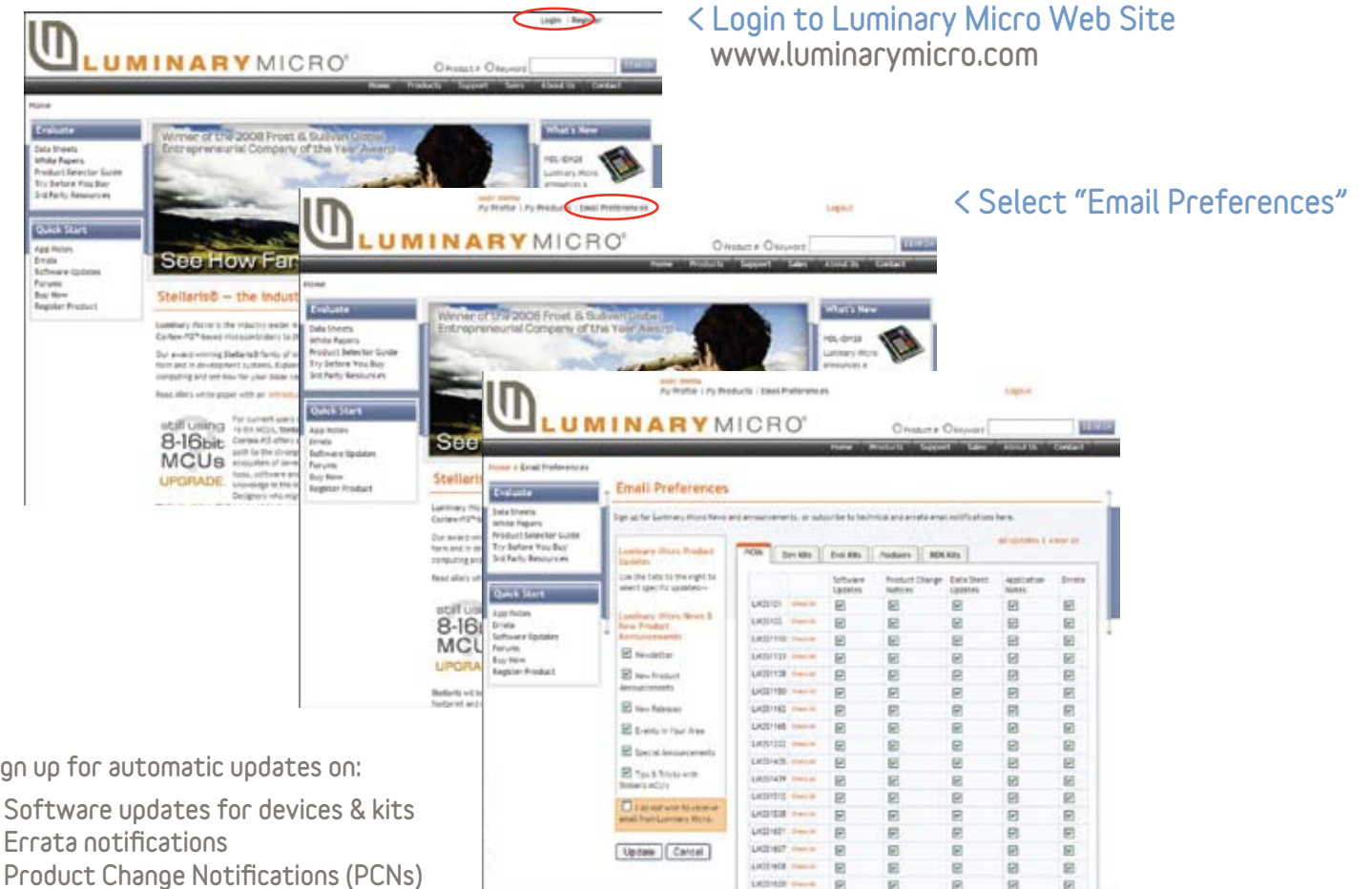

Sign up for automatic updates on:

- Software updates for devices & kits
- Errata notifications
- Product Change Notifications (PCNs)
- Application notes
- Datasheet updates

*Never miss out on PCNs or errata that affect your design!*

## Support at your fingertips

Getting technical support has never been easier! Luminary Micro hosts an active Stellaris user community in our Forums. Luminary Micro's applications engineers have been praised all over the world for the stellar support and superior knowledge they bring to engineering problems. Finally, Luminary Micro also provides a number of flash-based training modules, containing step-by-step information to help you get the most out of our development tools and Stellaris microcontrollers. You'll find all this and more at [www.luminarymicro.com/support/support.html](http://www.luminarymicro.com/support/support.html).

# Third Party Resources

Luminary Micro has partnered with industry-leading independent companies offering products and services that support Luminary Micro's Stellaris microcontrollers. Products and services include a broad range of application software, development hardware and software, and consulting and design house services helping customers accelerate development efforts and reduce time-to-market.

## Third Party Products

A fundamental advantage of our Stellaris microcontrollers is the unmatched strength of the ARM ecosystem. Luminary Micro's third party partners offer a wide array of products and services that run on and work with Stellaris microcontrollers. Starting with Luminary Micro's Stellaris microcontrollers, embedded system designers can enter the global ARM ecosystem with full confidence in an architecture-compatible roadmap from \$1 to 1 GHz, making it possible to never have to upgrade architectures again!

Luminary Micro works closely with a multitude of development tools companies to provide support for Stellaris microcontrollers.

In addition, Luminary Micro works with a number of outstanding companies providing real time operating systems and kernels that work with Stellaris microcontrollers. For evaluation applications utilizing each operating system, check the downloads available on the web page for each Stellaris evaluation kit.

Communications stacks for Stellaris microcontrollers are also available, with example applications available for download for Stellaris evaluation kits. Go to the web page for each Stellaris evaluation kit to see what evaluation packages for commercial communications stacks are available.



## Full Service Design Houses

Need an outstanding engineering team to bring your product to fruition? Luminary Micro's Design House Partners are ready to provide you with high-impact expertise in system architecture, design, and software development.

You can be assured that Luminary Micro's Design House Partners have the Stellaris microcontroller expertise that you need, as every partner must have completed a Stellaris-based design before inclusion in Luminary Micro's Design Partner program. Go to [www.luminarymicro.com/support/design\\_houses.html](http://www.luminarymicro.com/support/design_houses.html) to find the design house that is right for your needs!



# Index

- Stellarisware™ Software pg. 7
- Low Pin Count Real-Time MCUs pg. 9
- High Pin Count Real-Time MCUs pg. 11
- Ethernet Connected MCUs pg. 13
- USB Connected MCUs pg. 15
- USB On-The-Go MCUs pg. 17
- CAN Connected MCUs pg. 19
- Ethernet+CAN Internetworking MCUs pg. 21
- Connected Reference Design Kits pg. 23
- Motion Reference Design Kits pg. 26



## Stellarisware™

Luminary Micro's StellarisWare software is an extensive suite of software designed to simplify and speed development of Stellaris-based microcontroller applications, containing:

- Stellaris Peripheral Driver Library for Stellaris peripheral initialization and control functions
- Stellaris USB Library for USB device, USB host, or USB On-the-Go (OTG) applications
- Stellaris Graphics Library for graphical display support

StellarisWare software packages have the following features and benefits:

- Free license and royalty-free use (for use with Stellaris MCUs)
- Simplify and speed the development of applications - can be used for application development or as a programming example.
- Allow the creation of full-function, easy-to-maintain code.
- Written entirely in C except where absolutely not possible. Even written in C, the software is reasonably efficient in terms of memory and processor usage due to the compact nature of the Cortex-M3 Thumb2 instruction set.
- Take full advantage of the stellar interrupt performance of the Cortex-M3 core, without requiring any special pragmas or custom assembly code prologue/epilogue functions.
- Can be compiled with error-checking code (for development use) or without (for final production use in an MCU with a smaller memory configuration).
- Available as both object library and source code, so that the library can be used as-is or adapted as desired.
- Compiles on ARM/Keil, IAR, Code Red, Code Sourcery, and generic GNU development tools.

## Stellaris Peripheral Driver Library

The Stellaris Peripheral Driver Library is a royalty-free set of functions for controlling the peripherals found on the Stellaris family of ARM Cortex-M3 microcontrollers. Vastly superior to a GUI peripheral configuration tool, the Stellaris Peripheral Driver Library performs both peripheral initialization and peripheral control functions with a choice of polled or interrupt-driven peripheral support.

The Stellaris Peripheral Driver Library provides support for two programming models: the direct register access model and the software driver model. Each programming model can be used independently or combined, based on the needs of the application or the programming environment desired by the developer. The direct register access model includes header files for each specific Stellaris MCU and will generally result in smaller and more efficient code in a software development environment familiar to most deeply embedded firmware engineers and to engineers used to working with 8- and 16-bit MCUs. The software driver model insulates the software engineer from hardware details including the operation of each register, bit field, their interactions, and sequencing required for the proper operation of the peripheral, generally requiring less time to develop applications.

Some Stellaris microcontrollers provide the Stellaris Peripheral Driver Library on-chip in ROM (read-only memory). With the Stellaris Peripheral Driver Library in ROM, it is easier than ever to use the library to quickly develop efficient and functional applications in an environment where the entire flash memory is available for use for the application. The ROM-based Stellaris Peripheral Driver Library also supports user flash-based overrides of standard Stellaris Peripheral Driver Library functions, for complete flexibility in functionality.

## Stellaris Graphics Library

The Stellaris Graphics Library is a royalty-free set of graphics primitives and a widget set for creating graphical user interfaces on Stellaris microcontroller-based boards that have a graphical display. The graphical library consists of three building layers of functionality: the display driver layer, specific to the display in use; the graphics primitives layer, which draws points, lines, rectangles, circles, fonts, bitmap images, and text, either in the active display buffer or in an off-screen buffer for flicker-free operation; and the widget layer, which provides checkboxes, push buttons, radio buttons, sliders, list boxes, and a generic encapsulation of one or more graphics primitives to draw a user interface element on the display, along with the ability to provide application-defined responses to user interaction with the widget element.

## Stellaris USB Library

Luminary Micro Stellaris microcontrollers with USB functionality have all passed USB Device and USB Embedded Host compliance testing. The Stellaris USB Library is a royalty-free set of data types and functions for creating USB device, host, or On-the-Go (OTG) applications for Stellaris microcontroller-based systems. Several programming interfaces are provided, ranging from the thinnest layer which merely abstracts the underlying USB controller hardware, to high level interfaces offering simple APIs supporting specific devices. USB device examples provided include HID keyboard, HID mouse, CDC serial, and generic bulk. USB host examples provided include mass storage (USB flash stick), HID keyboard, and HID mouse. In addition, the Stellaris USB library provides a Windows™-based INF for the supported USB classes in a precompiled DLL that saves development time.

# StellarisWare™

## Stellaris Code Examples

All Stellaris development and evaluation kits ship with a rich set of applications that provide examples of how to use Stellaris microcontrollers and the Stellaris Peripheral Driver Library. Every kit ships with a quickstart application that is tailored to use the features provided on the evaluation board. Because the quickstart application uses many of the peripherals on the board simultaneously, the kits also ship with a set of simpler applications. These simpler applications provide stand-alone coding examples for all peripherals that are supported in the kit. To support user development with the kit, source code and project files are provided for the quickstart application and the simpler example applications. Documentation is provided for all example projects that explains the functionality of each example application.

## Stellaris In-System Programming Support

Stellaris microcontrollers provide a number of different mechanisms for in-system programming support. Many Stellaris microcontrollers ship with a royalty-free one-time-use serial flash loader application pre-programmed into flash. For these microcontrollers, the serial flash loader can be used in conjunction with Luminary Micro's LMFlash application, a standard JTAG debugger, or a production programmer to load the end application into flash during manufacturing.

Some Stellaris microcontrollers provide the Stellaris Boot Loader in read-only memory (ROM) integrated on the device. These microcontrollers provide flexible interface options for flash programming (both manufacturing and in-field updates) directly through the on-chip ROM.

### Stellaris Serial Flash Loader

All Stellaris microcontrollers ship with a royalty-free serial flash loader application pre-programmed into flash. The serial flash loader is a small application that allows programming of the flash without the need for a debugger interface or production programmer. With easy interface options including UART or SSI, the serial flash loader provides users with maximum flexibility in their production programming options. Luminary Micro provides a free flash programming utility for PCs called LMFlash that supports either command line or GUI usage and makes full use of all the commands supported by the serial flash loader application. For users desiring to build their own flash programmers, Luminary Micro also supplies a sample UART download utility that makes full use of all the commands supported by the serial flash loader application. Application note AN01242 provides source code and information about the serial flash loader and the sample UART download utility sflash.exe.

- Pre-loaded in flash on all shipped Stellaris MCUs that do not have the ROM-based Stellaris Boot Loader.
- Small piece of code that allows programming of the flash without the need for a debugger interface.
- Interface options include UART or SSI.
- Free LMFlash utility makes full use of all commands supported by the serial flash loader.

### Stellaris Boot Loader

For applications desiring in-field programmability, Luminary Micro also provides royalty-free Stellaris boot loader source code that can be added to your application at the beginning of the flash memory. This small piece of code can act as an application loader and stay resident to support in-field programmability for your end application. With flexible interface options including a UART, I2C, SSI, or Ethernet, and selectable methods for signaling an in-field update, the Stellaris boot loader provides users with maximum flexibility in boot loader requirements. The Stellaris Peripheral Driver Library includes source code and information about the Stellaris boot loader, including example applications that utilize the boot loader for in-field updates.

Some Stellaris microcontrollers provide the Stellaris Boot Loader in read-only memory (ROM) integrated on the device.

- Free license and royalty-free use (for use with Stellaris MCUs).
- Small piece of code that can be programmed at the beginning of flash to act as an application loader; available integrated on-chip in ROM on some Stellaris microcontrollers.
- Also used as an update mechanism for an application running on a Stellaris microcontroller.
- Interface options include UART (default), I<sup>2</sup>C, SSI, or Ethernet.



# Low Pin Count Real-Time MCUs

Luminary Micro offers thirty low pin count, low-cost, and feature-rich Stellaris ARM Cortex-M3 microcontrollers in two packages: a 28-pin SOIC and a 48-pin LQFP. The LM35100 Series (28-pin SOIC) and LM35300 Series (48-pin LQFP) are perfect for basic embedded control applications and 8-/16-bit upgrades. The LM35600 Series and LM35800 Series (both 48-pin LQFP) are optimized for embedded control applications requiring more sophisticated algorithms. Each Stellaris microcontroller offers efficient performance and extensive integration, favorably positioning the devices into cost-conscious applications requiring significant control processing capabilities such as motion control, medical instrumentation, HVAC and building control, factory automation, transportation, electronic point-of-sale machines, and gaming equipment.



Series and LM35800 Series (both 48-pin LQFP) are optimized for embedded control applications requiring more sophisticated algorithms. Each Stellaris microcontroller offers efficient performance and extensive integration, favorably positioning the devices into cost-conscious applications requiring significant control processing capabilities such as motion control, medical instrumentation, HVAC and building control, factory automation, transportation, electronic point-of-sale machines, and gaming equipment.

## Stellaris LM3S811 Evaluation Kit

- Evaluation board with 50 MHz LM3S811 microcontroller
- 96 x 16 pixel OLED display
- User-programmable push button and LED
- Convenient reset push button and power indicator LED
- Thumbwheel potentiometer input to the on-chip ADC
- Serial in-circuit debug interface over USB
- USB cable
- 20-pin JTAG/SWD target cable
- CD containing:
  - Evaluation version of the software tools
  - Complete documentation
  - Quickstart guide and source code
  - Stellaris Peripheral Driver Library and example source code
- Example applications demonstrating the use of various third party Real-Time Operating Systems are available for download from [www.luminarymicro.com/products/lm3s811\\_evaluation\\_kit.html](http://www.luminarymicro.com/products/lm3s811_evaluation_kit.html)



## Evaluation Kit Ordering Information

PART NUMBER	DESCRIPTION
EKK-LM3S811	Stellaris LM3S811 Evaluation Kit for Keil RealView MDK-ARM (32 KB code-size limited)
EKI-LM3S811	Stellaris LM3S811 Evaluation Kit for IAR Systems Embedded Workbench (32 KB code-size limited)
EKC-LM3S811	Stellaris LM3S811 Evaluation Kit for CodeSourcery G++ GNU (30-day Ltd.)
EKT-LM3S811	Stellaris LM3S811 Evaluation Kit for Code Red Technologies Red Suite (32 KB code-size limited)

		LM35101	LM35102	LM35300	LM35301	LM35308	LM35310	LM35315	LM35316	
MEMORY	Flash (KB)	8	8	16	16	16	16	16	16	
	SRAM (KB)	2	2	4	2	4	4	4	4	
	ROM Software Libraries	-	-	-	-	-	-	-	-	
	DMA	-	-	-	-	-	-	-	-	
CORE	Max Speed (MHz)	20	20	25	20	25	25	25	25	
	ARM® Cortex™ M3 Core	✓	✓	✓	✓	✓	✓	✓	✓	
	MPU	-	-	✓	✓	✓	✓	✓	✓	
	JTAG/SWO/SWD	✓	✓	✓	✓	✓	✓	✓	✓	
TIMERS	System Tick Timer (24-bit)	✓	✓	✓	✓	✓	✓	✓	✓	
	General-Purpose	2	2	3	2	3	3	3	3	
	Real-Time Clock (RTC)	✓	✓	✓	✓	✓	✓	✓	✓	
	Watchdog	✓	✓	✓	✓	✓	✓	✓	✓	
	PWM[a]	PWM	-	-	-	2	-	6	2	4
		Dead-Band Generator	-	-	-	✓	-	✓	✓	✓
		CCP	1	2	6	2	6	6	6	6
SERIAL INTERFACES	Ethernet (10/100 MAC+PHY)	-	-	-	-	-	-	-	-	
	IEEE1588	-	-	-	-	-	-	-	-	
	CAN MAC	-	-	-	-	-	-	-	-	
	USB	-	-	-	-	-	-	-	-	
	UART	1	1	2	1	2	2	2	2	
	IPC	-	1	1	-	1	-	-	1	
	SSI/SPI	1	1	1	1	1	1	1	1	
	QEI	-	-	-	-	-	-	-	-	
ANALOG	ADC (10-bit)	ADC Channels	-	-	-	3	8	-	4	4
		Precision (LSB)	-	-	-	+/-1	+/-1	-	+/-1	+/-1
	ADC Speed (samples per second)	-	-	-	250K	500K	-	250K	250K	
	Internal Temp Sensor	-	-	-	✓	✓	-	✓	✓	
Analog Comparators	2	1	3	2	1	3	1	1		
GPIOs (5-V TOLERANT)[b]	2-18	0-18	8-36	12-33	5-28	3-36	7-32	3-32		
BATTERY-BACKED HIBERNATION MODULE	-	-	-	-	-	-	-	-		
BROWN-OUT RESET	✓	✓	✓	✓	✓	✓	✓	✓		
LDO VOLTAGE REGULATOR	✓	✓	✓	✓	✓	✓	✓	✓		
OPERATING TEMPERATURE[c]	I,E	I,E	I,E	I,E	I,E	I,E	I,E	I,E		
PACKAGE	28-pin SOIC	28-pin SOIC	48-pin LQFP	48-pin LQFP	48-pin LQFP	48-pin LQFP	48-pin LQFP	48-pin LQFP		

# Low Pin Count Real-Time MCUs

	LM35317	LM35328	LM35600	LM35601	LM35608	LM35610	LM35611	LM35612	LM35613	LM35615	LM35617	LM35618	LM35628	LM35800	LM35801	LM35808	LM35811	LM35812	LM35815	LM35817	LM35818	LM35828	
Flash (KB)	16	16	32	32	32	32	32	32	32	32	32	32	32	64	64	64	64	64	64	64	64	64	
SRAM (KB)	4	4	8	8	8	8	8	8	8	8	8	8	8	8	8	8	8	8	8	8	8	8	
ROM Software Libraries	-	-	-	-	-	-	-	-	-	-	-	-	-	-	-	-	-	-	-	-	-	-	
DMA	-	-	-	-	-	-	-	-	-	-	-	-	-	-	-	-	-	-	-	-	-	-	
Max Speed (MHz)	25	25	50	50	50	50	50	50	50	50	50	50	50	50	50	50	50	50	50	50	50	50	
ARM® Cortex™ M3 Core	✓	✓	✓	✓	✓	✓	✓	✓	✓	✓	✓	✓	✓	✓	✓	✓	✓	✓	✓	✓	✓	✓	
MPU	✓	✓	✓	✓	✓	✓	✓	✓	✓	✓	✓	✓	✓	✓	✓	✓	✓	✓	✓	✓	✓	✓	
JTAG/SWO/SWD	✓	✓	✓	✓	✓	✓	✓	✓	✓	✓	✓	✓	✓	✓	✓	✓	✓	✓	✓	✓	✓	✓	
System Tick Timer (24-bit)	✓	✓	✓	✓	✓	✓	✓	✓	✓	✓	✓	✓	✓	✓	✓	✓	✓	✓	✓	✓	✓	✓	
General-Purpose	3	3	3	3	3	3	3	3	3	3	3	3	3	3	3	3	3	3	3	3	3	3	
Real-Time Clock (RTC)	✓	✓	✓	✓	✓	✓	✓	✓	✓	✓	✓	✓	✓	✓	✓	✓	✓	✓	✓	✓	✓	✓	
Watchdog	✓	✓	✓	✓	✓	✓	✓	✓	✓	✓	✓	✓	✓	✓	✓	✓	✓	✓	✓	✓	✓	✓	
PWM[a]	PWM	6	-	-	6	-	6	2	4	6	6	6	-	-	6	-	6	2	6	6	6	-	
	Dead-Band Generator	✓	-	-	✓	-	✓	✓	✓	✓	✓	✓	-	-	✓	-	✓	✓	✓	✓	✓	-	
	CCP	6	6	6	6	6	6	6	6	6	6	4	4	6	6	6	6	6	6	6	4	6	
Ethernet (10/100 MAC+PHY)	-	-	-	-	-	-	-	-	-	-	-	-	-	-	-	-	-	-	-	-	-	-	
IEEE1588	-	-	-	-	-	-	-	-	-	-	-	-	-	-	-	-	-	-	-	-	-	-	
CAN MAC	-	-	-	-	-	-	-	-	-	-	-	-	-	-	-	-	-	-	-	-	-	-	
USB	-	-	-	-	-	-	-	-	-	-	-	-	-	-	-	-	-	-	-	-	-	-	
UART	1	2	2	2	2	2	2	2	2	2	2	2	2	2	2	2	2	2	2	2	2	2	
IPC	-	1	1	1	1	1	1	1	1	1	-	-	1	1	1	1	1	1	1	-	-	1	
SSI/SPI	1	1	1	1	1	1	1	1	1	1	1	1	1	1	1	1	1	1	1	1	1	1	
QEI	-	-	-	1	-	-	-	-	-	-	-	1	-	-	1	-	-	-	-	-	1	-	
ADC (10-bit)	ADC Channels	6	8	-	-	8	2	4	2	4	2	6	6	8	-	-	8	4	2	2	6	6	8
	Precision (LSB)	+/-1	+/-1	-	-	+/-1	+/-1	+/-1	+/-1	+/-1	+/-1	+/-1	+/-1	-	-	+/-1	+/-1	+/-1	+/-1	+/-1	+/-1	+/-1	+/-1
ADC Speed (samples per second)	250K	500K	-	-	500K	500K	500K	500K	500K	500K	500K	500K	1M	-	-	500K	500K	250K	500K	1M	1M	1M	
Internal Temp Sensor	✓	✓	-	-	✓	✓	✓	✓	✓	✓	✓	✓	-	-	✓	✓	✓	✓	✓	✓	✓	✓	
Analog Comparators	1	-	3	3	1	-	-	1	1	3	1	1	-	3	3	1	1	1	3	1	1	-	
GPIOs (5-V TOLERANT)[b]	3-30	7-28	8-36	0-36	5-28	6-34	4-32	7-34	3-32	0-34	1-30	0-30	9-28	8-36	0-36	5-28	1-32	7-34	0-34	1-30	0-30	7-28	
BATTERY-BACKED HIBERNATION MODULE	-	-	-	-	-	-	-	-	-	-	-	-	-	-	-	-	-	-	-	-	-	-	
BROWN-OUT RESET	✓	✓	✓	✓	✓	✓	✓	✓	✓	✓	✓	✓	✓	✓	✓	✓	✓	✓	✓	✓	✓	✓	
LDO VOLTAGE REGULATOR	✓	✓	✓	✓	✓	✓	✓	✓	✓	✓	✓	✓	✓	✓	✓	✓	✓	✓	✓	✓	✓	✓	
OPERATING TEMPERATURE[c]	I,E	I,E	I,E	I,E	I,E	I,E	I,E	I,E	I,E	I,E	I,E	I,E	I,E	I,E	I,E	I,E	I,E	I,E	I,E	I,E	I,E	I,E	
PACKAGE	48-pin LQFP	48-pin LQFP	48-pin LQFP	48-pin LQFP	48-pin LQFP	48-pin LQFP	48-pin LQFP	48-pin LQFP	48-pin LQFP	48-pin LQFP	48-pin LQFP	48-pin LQFP	48-pin LQFP	48-pin LQFP	48-pin LQFP	48-pin LQFP	48-pin LQFP	48-pin LQFP	48-pin LQFP	48-pin LQFP	48-pin LQFP	48-pin LQFP	

[a] PWM motion-control functionality can be achieved through dedicated motion control hardware (the PWM pins) or through the motion control features of the general-purpose timers (the CCP pins). See data sheet for details. [b] Minimum is number of pins dedicated to GPIO; additional pins are available if certain peripherals are not used. See data sheet for details. [c] Industrial (I) is -40 to +85 °C and Extended (E) is -40 to +105 °C.

# High Pin Count Real-Time MCUs

Luminary Micro's LM3S1000 Series of Stellaris ARM Cortex-M3 microcontrollers feature new combinations of expanded general purpose I/O, larger on-chip memory, and low-power optimization for battery-backed applications. Offered in a 64-pin LQFP, 100-pin LQFP or 108-pin BGA package, the LM3S1000 Series offers efficient performance and extensive integration, favorably positioning the device into cost-conscious applications requiring significant control processing capabilities such as motion control, medical instrumentation, HVAC and building control, factory automation, transportation, electronic point-of-sale machines, and gaming equipment.



## Stellaris LM3S1968 Evaluation Kit

Stellaris LM3S1968 Evaluation Kits provide a compact and versatile evaluation platform for LM3S1000 Series of Stellaris ARM Cortex-M3-based microcontrollers. The quickstart application that runs out-of-the-box includes an example utilizing the low power hibernate mode of the LM3S1968 microcontroller. Each board has an In-Circuit Debug Interface (ICDI) that provides hardware debugging functionality not only for the on-board Stellaris devices, but also for any Stellaris microcontroller-based target board. The evaluation kits contain all cables, software, and documentation needed to develop and run applications for Stellaris microcontrollers easily and quickly. In addition, example applications demonstrating the use of various third party Real Time Operating Systems are available for download from [www.luminary-micro.com/products/lm3s1968\\_evaluation\\_kit.html](http://www.luminary-micro.com/products/lm3s1968_evaluation_kit.html).

## Stellaris LM3S1968 Evaluation Kit Features

- LM3S1968 Evaluation Board with a quickstart sample application
  - Stellaris LM3S1968 MCU with 256K flash, 64K SRAM, 8 ADCs, and up to 52 GPIOs
  - All LM3S1968 I/O available on labeled break-out pads
  - Support for battery-backed hibernate mode
  - Simple setup: USB cable provides serial communication, debugging, and power
  - OLED graphics display with 128 x 64 pixel resolution and 16 shades of gray
  - User LED, navigation switches, and select pushbuttons, magnetic speaker
  - Standard ARM 20-pin JTAG debug connector with input and output modes
- USB and JTAG cables
- CD containing:
  - Evaluation version of the software tools, Complete documentation, Quickstart guide and source code, Stellaris Peripheral Driver Library and example source code



## Evaluation Kit Ordering Information

PART NUMBER	DESCRIPTION
EKK-LM3S1968	Stellaris LM3S1968 Evaluation Kit for Keil RealView MDK-ARM (32 KB code-size limitation)
EKI-LM3S1968	Stellaris LM3S1968 Evaluation Kit for IAR Systems Embedded Workbench (32 KB code-size limited)
EKC-LM3S1968	Stellaris LM3S1968 Evaluation Kit for CodeSourcery G++ GNU (30-day limited)
EKT-LM3S1968	Stellaris LM3S1968 Evaluation Kit for Code Red Technologies Red Suite (board-locked)

	LM3S1100	LM3S1133	LM3S1138	LM3S1150	LM3S1162	LM3S1165		
MEMORY	Flash (KB)	64	64	64	64	64		
	SRAM (KB)	16	16	16	16	16		
	ROM Software Libraries	-	-	-	-	-		
	DMA	-	-	-	-	-		
CORE	Max Speed (MHz)	25	50	50	50	50		
	ARM® Cortex™ M3 Core	✓	✓	✓	✓	✓		
	MPU	✓	✓	✓	✓	✓		
TIMERS	JTAG/SWO/SWD	✓	✓	✓	✓	✓		
	System Tick Timer (24-bit)	✓	✓	✓	✓	✓		
	General-Purpose	3	4	4	4	4		
	Real-Time Clock (RTC)	✓	✓	✓	✓	✓		
	Watchdog	✓	✓	✓	✓	✓		
	PWM[a]	PWM	-	2	-	6	6	
		Dead-Band Generator	-	✓	-	✓	✓	
		CCP	2	8	6	6	8	
	SERIAL INTERFACES	Ethernet (10/100 MAC+PHY)	-	-	-	-	-	
		IEEE1588	-	-	-	-	-	
CAN MAC		-	-	-	-	-		
USB		-	-	-	-	-		
UART		2	3	3	3	3		
PC		-	1	2	1	1		
SSI/SPI		1	2	2	2	2		
QEI		-	-	-	1	-		
ANALOG	ADC (10-bit)	ADC Channels	-	2	8	-	2	4
		Precision (LSB)	-	+/-1	+/-1	-	+/-1	+/-1
	ADC Speed (samples per second)	-	250K	1M	-	500K	500K	
	Internal Temp Sensor	-	✓	✓	-	✓	✓	
Analog Comparators	2	1	3	3	3	1		
GPIOs (5-V TOLERANT)[b]	20-41	9-44	9-46	7-52	4-46	4-43		
BATTERY-BACKED HIBERNATION MODULE	✓	✓	✓	✓	✓	✓		
BROWN-OUT RESET	✓	✓	✓	✓	✓	✓		
LDO VOLTAGE REGULATOR	✓	✓	✓	✓	✓	✓		
OPERATING TEMPERATURE[c][d]	I,E	I,E	I,E	I,E	I,E	I,E		
PACKAGE	100-LQFP 108-BGA	100-LQFP 108-BGA	100-LQFP 108-BGA	100-LQFP 108-BGA	100-LQFP 108-BGA	100-LQFP 108-BGA		

# High Pin Count Real-Time MCUs

	LM3S1332	LM3S1435	LM3S1439	LM3S1512	LM3S1538	LM3S1601	LM3S1607	LM3S1608	LM3S1620	LM3S1625	LM3S1626	LM3S1627	LM3S1635	LM3S1637	LM3S1751	LM3S1776	LM3S1850	LM3S1911	LM3S1918	LM3S1937	LM3S1958	LM3S1960	LM3S1968	
MEMORY	Flash (KB)	96	96	96	96	128	128	128	128	128	128	128	128	128	128	128	256	256	256	256	256	256	256	
	SRAM (KB)	16	32	32	64	64	32	32	32	32	32	32	32	32	64	64	32	64	64	64	64	64	64	
	ROM Software Libraries	-	-	-	-	-	✓	-	-	✓	✓	✓	-	-	-	✓	-	-	-	-	-	-	-	
	DMA	-	-	-	-	-	✓	-	-	✓	✓	✓	-	-	-	✓	-	-	-	-	-	-	-	
CORE	Max Speed (MHz)	50	50	50	25	50	50	50	25	50	50	50	50	50	50	50	50	50	50	50	50	50	50	
	ARM® Cortex™ M3 Core	✓	✓	✓	✓	✓	✓	✓	✓	✓	✓	✓	✓	✓	✓	✓	✓	✓	✓	✓	✓	✓	✓	
	MPU	✓	✓	✓	✓	✓	✓	✓	✓	✓	✓	✓	✓	✓	✓	✓	✓	✓	✓	✓	✓	✓	✓	
TIMERS	JTAG/SWO/SWD	✓	✓	✓	✓	✓	✓	✓	✓	✓	✓	✓	✓	✓	✓	✓	✓	✓	✓	✓	✓	✓	✓	
	System Tick Timer (24-bit)	✓	✓	✓	✓	✓	✓	✓	✓	✓	✓	✓	✓	✓	✓	✓	✓	✓	✓	✓	✓	✓	✓	
	General-Purpose	4	3	3	4	4	4	4	4	3	4	4	4	4	3	3	3	4	4	3	4	4	4	
	Real-Time Clock (RTC)	✓	✓	✓	✓	✓	✓	✓	✓	✓	✓	✓	✓	✓	✓	✓	✓	✓	✓	✓	✓	✓	✓	
	Watchdog	✓	✓	✓	✓	✓	✓	✓	✓	✓	✓	✓	✓	✓	✓	✓	✓	✓	✓	✓	✓	✓	✓	
	PWM[a]	PWM	-	2	6	-	-	-	-	6	4	4	6	6	6	4	8	6	-	-	6	-	6	6
		Dead-Band Generator	-	✓	✓	-	-	-	-	✓	✓	✓	✓	✓	✓	✓	✓	✓	-	-	✓	-	✓	✓
		CCP	8	4	6	8	8	8	6	8	4	4	4	8	6	6	2	6	8	8	4	8	8	4
	SERIAL INTERFACES	Ethernet (10/100 MAC+PHY)	-	-	-	-	-	-	-	-	-	-	-	-	-	-	-	-	-	-	-	-	-	-
		IEEE1588	-	-	-	-	-	-	-	-	-	-	-	-	-	-	-	-	-	-	-	-	-	-
CAN MAC		-	-	-	-	-	-	-	-	-	-	-	-	-	-	-	-	-	-	-	-	-	-	
USB		-	-	-	-	-	-	-	-	-	-	-	-	-	-	-	-	-	-	-	-	-	-	
UART		2	2	2	3	3	3	3	2	2	1	2	3	3	3	1	2	3	2	2	3	3	3	
PC		-	1	1	2	2	2	2	1	2	1	1	2	1	1	1	1	2	2	1	2	2	2	
SSI/SPI		1	1	2	2	2	1	2	2	1	1	1	2	1	2	1	1	2	2	1	2	2	2	
QEI		-	-	1	1	1	-	-	-	1	-	1	-	1	-	-	1	-	-	-	-	2	2	
ANALOG	ADC (10-bit)	ADC Channels	3	2	4	2	8	-	8	8	-	6	6	4	4	4	6	-	-	8	4	8	-	
		Precision (LSB)	+/-1	+/-1	+/-1	+/-1	+/-1	-	+/-1	+/-1	-	+/-1	+/-1	+/-1	+/-1	+/-1	+/-1	-	-	+/-1	+/-1	+/-1	-	
	ADC Speed (samples per second)	250K	500K	500K	250K	500K	-	500K	500K	-	500K	500K	500K	500K	1M	500K	1M	-	-	500K	1M	1M	-	
	Internal Temp Sensor	✓	✓	✓	✓	✓	-	✓	✓	-	✓	✓	✓	✓	✓	✓	-	-	✓	✓	✓	-	✓	
Analog Comparators	3	1	1	3	-	2	-	2	3	1	-	-	2	1	1	-	3	2	2	1	-	3		
GPIOs (5-V TOLERANT)[b]	29-57	21-46	14-52	15-58	9-43	23-60	0-33	17-52	11-52	0-33	0-33	0-33	12-56	7-43	21-56	1-33	17-56	23-60	17-52	27-56	21-52	7-60		
BATTERY-BACKED HIBERNATION MODULE	✓	✓	✓	✓	✓	✓	✓	✓	✓	-	-	-	✓	✓	✓	✓	✓	✓	✓	✓	✓	✓		
BROWN-OUT RESET	✓	✓	✓	✓	✓	✓	✓	✓	✓	✓	✓	✓	✓	✓	✓	✓	✓	✓	✓	✓	✓	✓		
LDO VOLTAGE REGULATOR	✓	✓	✓	✓	✓	✓	✓	✓	✓	✓	✓	✓	✓	✓	✓	✓	✓	✓	✓	✓	✓	✓		
OPERATING TEMPERATURE[c][d]	I,E	I,E	I,E	I,E	I,E	I,E	I	I,E	I,E	I	I	I	I,E	I,E	I,E	I	I,E	I,E	I,E	I,E	I,E	I,E		
PACKAGE	100-LQFP 108-BGA	100-LQFP 108-BGA	100-LQFP 108-BGA	100-LQFP 108-BGA	100-LQFP 108-BGA	100-LQFP 108-BGA	64-LQFP	100-LQFP 108-BGA	100-LQFP 108-BGA	64-LQFP	64-LQFP	64-LQFP	100-LQFP 108-BGA	100-LQFP 108-BGA	100-LQFP 108-BGA	64-LQFP	100-LQFP 108-BGA	100-LQFP 108-BGA	100-LQFP 108-BGA	100-LQFP 108-BGA	100-LQFP 108-BGA	100-LQFP 108-BGA		

[a] PWM motion-control functionality can be achieved through dedicated motion control hardware (the PWM pins) or through the motion control features of the general-purpose timers (the CCP pins). See data sheet for details. [b] Minimum is number of pins dedicated to GPIO; additional pins are available if certain peripherals are not used. See data sheet for details. [c] Industrial (I) is -40 to +85 °C and Extended (E) is -40 to +105 °C. [d] 108-pin BGA and 64-pin LQFP package only available in Industrial temperature.



# Ethernet Connected MCUs

Luminary Micro's LM3S6000 Series of Stellaris ARM Cortex-M3 microcontrollers feature new combinations of industrial real-time connectivity, expanded general purpose I/O, larger on-chip memory, and low-power optimization for battery-backed applications. The LM3S6000 series provides the world's first MCUs featuring a fully-integrated 10/100 Mbps Ethernet solution with ARM architecture compatibility. The LM3S6000 devices combine both the Ethernet Media Access Control (MAC) and Physical (PHY) layers, marking the first time that integrated connectivity is available with an ARM Cortex-M3 MCU and the only integrated 10/100 Ethernet MAC and PHY available in an ARM architecture MCU. In addition, selected LM3S6000 Series Stellaris MCUs also feature hardware assist for IEEE 1588 Precision Time Protocol support.

## Stellaris LM3S6965 Ethernet Evaluation Kit

Stellaris LM3S6965 Evaluation Kits provide a compact and versatile evaluation platform for Ethernet-enabled Stellaris ARM Cortex-M3-based microcontrollers. The kit includes two examples of an embedded web-server demonstration application. The quickstart application that runs out-of-the-box includes an embedded web server utilizing the Open Source lwIP Ethernet stack. The kit also contains a web server application with FreeRTOS.org™ RTOS and the Open Source uIP Ethernet stack. Each board has an In-Circuit Debug Interface (ICDI) that provides hardware debugging functionality not only for the on-board Stellaris device, but also for any Stellaris microcontroller-based target board. The evaluation kits contain all cables, software, and documentation needed to develop and run applications for Stellaris microcontrollers easily and quickly. In addition, example applications demonstrating the use of various third party Real Time Operating Systems and commercial Ethernet stacks are available for download from [www.luminarymicro.com/products/lm3s6965\\_ethernet\\_evaluation\\_kit.html](http://www.luminarymicro.com/products/lm3s6965_ethernet_evaluation_kit.html).



## Stellaris LM3S6965 Ethernet Evaluation Kit Features

- LM3S6965 Evaluation Board
- Stellaris LM3S6965 microcontroller with fully integrated 10/100 (MAC+PHY) Ethernet controller
- Simple setup: USB cable provides serial communication, debugging, and power
- OLED graphics display with 128 x 64 pixel resolution and 16 shades of gray
- User LED, navigation switches, and select pushbuttons
- Magnetic speaker
- All LM3S6965 I/O available on labeled break-out pads
- Standard ARM 20-pin JTAG debug connector with input and output modes
- MicroSD card slot
- Retracting Ethernet cable, USB cable, and JTAG cable
- Quickstart sample application runs with or without Ethernet (direct connection to your PC), right out of the box
- CD containing:
  - Evaluation version of the software tools
  - Quickstart guide and source code
  - Complete documentation
  - Stellaris Peripheral Driver Library and example source code



## Evaluation Kit Ordering Information

PART NUMBER	DESCRIPTION
EKK-LM3S6965	Stellaris LM3S6965 Ethernet Evaluation Kit for Keil RealView MDK-ARM (32 KB code-size limited)
EKI-LM3S6965	Stellaris LM3S6965 Ethernet Evaluation Kit for IAR Systems Embedded Workbench (32 KB code-size limited)
EKC-LM3S6965	Stellaris LM3S6965 Ethernet Evaluation Kit for CodeSourcery G++ GNU (30-day limited)
EKT-LM3S6965	Stellaris LM3S6965 Evaluation Kit for Code Red Technologies Red Suite (board-locked)

# Ethernet Connected MCUs

		LM3S6100	LM3S6110	LM3S6120	LM3S6122	LM3S6132	LM3S6137	LM3S6610	LM3S6611	LM3S6618	LM3S6633	LM3S6637	LM3S6730	LM3S6753	LM3S6911	LM3S6918	LM3S6938	LM3S6950	LM3S6952	LM3S6965	
MEMORY	Flash (KB)	64	64	96	96	96	96	128	128	128	128	128	128	128	256	256	256	256	256	256	
	SRAM (KB)	16	16	32	32	32	64	32	32	32	32	32	64	64	64	64	64	64	64	64	
	ROM Software Libraries	-	-	-	-	-	-	-	-	-	-	-	-	-	-	-	-	-	-	-	
	DMA	-	-	-	-	-	-	-	-	-	-	-	-	-	-	-	-	-	-	-	
CORE	Max Speed (MHz)	25	25	25	25	50	50	25	50	50	50	50	50	50	50	50	50	50	50	50	
	ARM® Cortex™ M3 Core	✓	✓	✓	✓	✓	✓	✓	✓	✓	✓	✓	✓	✓	✓	✓	✓	✓	✓	✓	
	MPU	✓	✓	✓	✓	✓	✓	✓	✓	✓	✓	✓	✓	✓	✓	✓	✓	✓	✓	✓	
TIMERS	JTAG/SWO/SWD	✓	✓	✓	✓	✓	✓	✓	✓	✓	✓	✓	✓	✓	✓	✓	✓	✓	✓	✓	
	System Tick Timer (24-bit)	✓	✓	✓	✓	✓	✓	✓	✓	✓	✓	✓	✓	✓	✓	✓	✓	✓	✓	✓	
	General-Purpose	3	3	3	3	3	4	4	4	4	3	4	3	4	4	4	4	4	3	4	
	Real-Time Clock (RTC)	✓	✓	✓	✓	✓	✓	✓	✓	✓	✓	✓	✓	✓	✓	✓	✓	✓	✓	✓	
	Watchdog	✓	✓	✓	✓	✓	✓	✓	✓	✓	✓	✓	✓	✓	✓	✓	✓	✓	✓	✓	
	PWM[a]	PWM	-	2	-	-	2	6	4	-	-	-	-	-	6	-	-	-	6	4	6
		Dead-Band Generator	-	✓	-	-	✓	✓	✓	-	-	-	-	-	✓	-	-	-	✓	✓	✓
		CCP	4	4	4	4	4	6	6	6	6	6	6	4	4	6	6	6	6	4	4
	SERIAL INTERFACES	Ethernet (10/100 MAC+PHY)	✓	✓	✓	✓	✓	✓	✓	✓	✓	✓	✓	✓	✓	✓	✓	✓	✓	✓	✓
		IEEE1588	-	-	-	-	-	✓	-	-	-	-	-	-	✓	-	-	-	✓	-	-
CAN MAC		-	-	-	-	-	-	-	-	-	-	-	-	-	-	-	-	-	-	-	
USB		-	-	-	-	-	-	-	-	-	-	-	-	-	-	-	-	-	-	-	
UART		1	1	1	1	2	2	3	3	2	2	2	1	2	3	2	3	3	3	3	
I²C		-	-	-	-	1	1	1	2	2	1	1	-	1	2	2	1	1	1	2	
SSI/SPI		1	1	1	1	1	1	1	2	2	1	1	1	1	2	2	1	2	1	1	
QEI		-	-	-	-	-	-	1	-	-	-	-	-	1	-	-	-	1	1	2	
ANALOG		ADC Channels	-	-	-	2	3	4	-	-	8	3	4	-	4	-	8	8	-	3	4
		Precision (LSB)	-	-	-	+/-1	+/-1	+/-1	-	-	+/-1	+/-1	+/-1	-	+/-1	-	+/-1	+/-1	-	+/-1	+/-1
	ADC Speed (samples per second)	-	-	-	250K	250K	500K	-	-	500K	500K	1M	-	500K	-	500K	1M	-	500K	1M	
Internal Temp Sensor	Internal Temp Sensor	-	-	-	✓	✓	✓	-	-	✓	✓	✓	-	✓	-	✓	✓	-	✓	✓	
	Analog Comparators	1	3	2	2	2	2	3	2	2	1	3	2	2	2	3	3	3	3	2	
GPIOs (5-V TOLERANT)[b]	10-30	8-35	23-46	12-43	14-43	6-41	5-46	10-46	5-38	15-41	11-41	23-46	5-41	10-46	5-38	7-38	1-46	6-43	0-42		
BATTERY-BACKED HIBERNATION MODULE	-	-	-	-	-	✓	✓	✓	✓	✓	✓	✓	✓	✓	✓	✓	✓	✓	✓	✓	
BROWN-OUT RESET	✓	✓	✓	✓	✓	✓	✓	✓	✓	✓	✓	✓	✓	✓	✓	✓	✓	✓	✓	✓	
LDO VOLTAGE REGULATOR	✓	✓	✓	✓	✓	✓	✓	✓	✓	✓	✓	✓	✓	✓	✓	✓	✓	✓	✓	✓	
OPERATING TEMPERATURE[c][d]	I,E	I,E	I,E	I,E	I,E	I,E	I,E	I,E	I,E	I,E	I,E	I,E	I,E	I,E	I,E	I,E	I,E	I,E	I,E	I,E	
PACKAGE	100-LQFP BGA	100-LQFP BGA	100-LQFP BGA	100-LQFP BGA	100-LQFP BGA	100-LQFP BGA	100-LQFP BGA	100-LQFP BGA	100-LQFP BGA	100-LQFP BGA	100-LQFP BGA	100-LQFP BGA	100-LQFP BGA	100-LQFP BGA	100-LQFP BGA	100-LQFP BGA	100-LQFP BGA	100-LQFP BGA	100-LQFP BGA	100-LQFP BGA	

[a] PWM motion-control functionality can be achieved through dedicated motion control hardware (the PWM pins) or through the motion control features of the general-purpose timers (the CCP pins). See data sheet for details. [b] Minimum is number of pins dedicated to GPIO; additional pins are available if certain peripherals are not used. See data sheet for details. [c] Industrial (I) is -40 to +85 °C and Extended (E) is -40 to +105 °C. [d] 108-pin BGA package only available in Industrial temperature.





Luminary Micro's LM3S3000 Series of Stellaris ARM Cortex-M3 microcontrollers feature USB 2.0 full-speed (12 Mbps) Host/Device connectivity. The LM3S5000 Series of Stellaris ARM Cortex-M3 microcontrollers add Controller Area Network (CAN) connectivity in conjunction with USB 2.0 full-speed capability. Stellaris USB-connected microcontrollers provide either embedded USB Host or embedded USB Device operation. Available in a compact 64-pin LQFP package or a feature-rich 100-pin LQFP package, these new Stellaris microcontrollers offer efficient performance along with extensive integration, and include the popular Stellaris Peripheral Driver Library on-chip in ROM.

## Stellaris LM3S3748 USB Host/Device Evaluation Kit

The Stellaris® LM3S3748 Evaluation Board (EVB) is a compact and versatile evaluation platform for the Stellaris LM3S3748 ARM® Cortex™-M3-based microcontroller. The evaluation board design highlights the LM3S3748 microcontroller's key features including a USB 2.0 full-speed (12 Mbps) Host/Device controller, Analog-to-Digital Converter (ADC), and serial interfaces. In USB Device mode, a small switch selects between bus-powered and self-powered options. The quickstart application that runs out-of-the-box uses four ADC signals paired as two differential channels to implement a 1MS/s oscilloscope application on the LCD display, illustrating high frequency data acquisition and processing with a sophisticated user interface developed using the Stellaris Graphics Library. The quickstart application utilizes the Stellaris USB library to operate in both USB Host and USB Device modes, saving signal display bitmaps and raw data to the included USB stick and connecting to a PC for remotely controlled data display. The LM3S3748 board also has an In-Circuit Debug Interface (ICDI) that provides hardware debugging not only for the on-board Stellaris device, but also for any Stellaris microcontroller-based target board. In Debug Interface mode, the on-board microcontroller is bypassed, allowing programming or debugging of an external target. The evaluation kits contain all cables, software, and documentation needed to develop and run applications for Stellaris microcontrollers easily and quickly. In addition, example applications demonstrating the use of various third party Real Time Operating Systems and commercial communications stacks are available for download from [www.luminarymicro.com/products/lm3s3748\\_evaluation\\_kit.html](http://www.luminarymicro.com/products/lm3s3748_evaluation_kit.html).



## Stellaris LM3S3748 USB Host/Device Evaluation Kit

- 50 MHz Stellaris LM3S3748 microcontroller with 128 KB Flash and 64 KB SRAM
- 2 channel oscilloscope quickstart application
- USB Host and Device connectors
- Bus-powered or self-powered USB support
- Simple setup: USB cable provides serial communication, debugging, and power
- Color LCD graphics display with 128 x 128 pixel resolution
- User LED and navigation switch with press-to-select functionality
- 8-Ohm magnetic speaker with amplifier
- microSD card slot
- USB interface for debugging and power supply
- DC jack for optional 5 V power supply
- Standard ARM® 20-pin JTAG/SWD debug connector with input and output modes
- LM3S3748 microcontroller I/O available on labeled break-out pads
- USB cables (1 each for device and debugger use)
- USB flash memory stick
- Four oscilloscope test leads for quickstart application
- 20-pin JTAG/SWD target cable
- CD containing:
  - Complete documentation
  - Evaluation version of the software tools
  - Quickstart (oscilloscope application) guide and source code
  - Stellaris Peripheral Driver Library and example source code

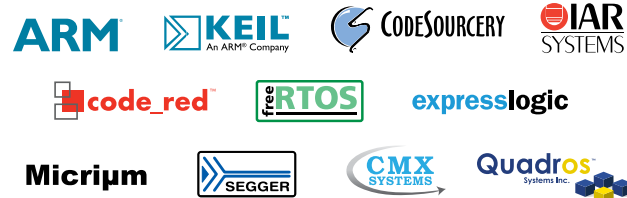

## Evaluation Kit Ordering Information

PART NUMBER	DESCRIPTION
EKK-LM3S3748	Stellaris LM3S3748 USB Host/Device Evaluation Kit for Keil™ RealView® MDK-ARM (32 KB code-size limited)
EKI-LM3S3748	Stellaris LM3S3748 USB Host/Device Evaluation Kit for IAR Systems Embedded Workbench® (32 KB code-size limited)
EKC-LM3S3748	Stellaris LM3S3748 USB Host/Device Evaluation Kit for CodeSourcery G++ GNU (30-day limited)
EKT-LM3S3748	Stellaris LM3S3748 USB Host/Device Evaluation Kit for Code Red Technologies Red Suite (board-locked)

		LM3S3739	LM3S3748	LM3S3749	LM3S5632	LM3S5732	LM3S5737	LM3S5739	LM3S5747	LM3S5749	
MEMORY	Flash (KB)	128	128	128	128	128	128	128	128	128	
	SRAM (KB)	64	64	64	32	64	64	64	64	64	
	ROM Software Libraries	✓	✓	✓	✓	✓	✓	✓	✓	✓	
	DMA	✓	✓	✓	✓	✓	✓	✓	✓	✓	
CORE	Max Speed (MHz)	50	50	50	50	50	50	50	50	50	
	ARM® Cortex™ M3 Core	✓	✓	✓	✓	✓	✓	✓	✓	✓	
	MPU	✓	✓	✓	✓	✓	✓	✓	✓	✓	
TIMERS	JTAG/SWO/SWD	✓	✓	✓	✓	✓	✓	✓	✓	✓	
	System Tick Timer (24-bit)	✓	✓	✓	✓	✓	✓	✓	✓	✓	
	General-Purpose	4	4	4	3	3	3	4	3	4	
	Real-Time Clock (RTC)	✓	✓	✓	✓	✓	✓	✓	✓	✓	
	Watchdog	✓	✓	✓	✓	✓	✓	✓	✓	✓	
	PWM[a]	PWM	–	8	8	–	–	–	–	6	8
		Dead-Band Generator	–	✓	✓	–	–	–	–	✓	✓
		CCP	8	8	7	5	5	3	8	2	5
	SERIAL INTERFACES	Ethernet (10/100 MAC+PHY)	–	–	–	–	–	–	–	–	–
		IEEE1588	–	–	–	–	–	–	–	–	–
CAN MAC		–	–	–	1	1	1	1	1	2	
USB		H/D	H/D	H/D	H/D	H/D	H/D	H/D	H/D	H/D	
UART		3	2	3	2	2	1	3	1	2	
I²C		2	2	2	2	2	2	2	1	2	
SSI/SPI		2	2	2	1	1	2	2	1	2	
QEI		–	1	1	–	–	–	–	–	1	
ANALOG	ADC (10-bit)	ADC Channels	8	8	8	6	6	8	8	8	
		Precision (LSB)	+/-1	+/-1	+/-1	+/-1	+/-1	+/-1	+/-1	+/-1	+/-1
		ADC Speed (samples per second)	500K	1M	1M	500K	500K	500K	500K	500K	1M
	Internal Temp Sensor	✓	✓	✓	✓	✓	✓	✓	✓	✓	
Analog Comparators	2	2	2	–	–	–	2	–	2		
GPIOs (5-V TOLERANT)[b]	14-61	3-61	0-61	1-33	1-33	27-61	12-61	27-61	0-61		
BATTERY-BACKED HIBERNATION MODULE	✓	✓	✓	✓	✓	✓	✓	✓	✓		
BROWN-OUT RESET	✓	✓	✓	✓	✓	✓	✓	✓	✓		
LDO VOLTAGE REGULATOR	✓	✓	✓	✓	✓	✓	✓	✓	✓		
OPERATING TEMPERATURE[c]	I	I	I	I	I	I	I	I	I		
PACKAGE	100-LQFP	100-LQFP	100-LQFP	64-LQFP	64-LQFP	100-LQFP	100-LQFP	100-LQFP	100-LQFP		

[a] PWM motion-control functionality can be achieved through dedicated motion control hardware (the PWM pins) or through the motion control features of the general-purpose timers (the CCP pins). See data sheet for details. [b] Minimum is number of pins dedicated to GPIO; additional pins are available if certain peripherals are not used. See data sheet for details. [c] Industrial (I) is -40 to +85 °C and Extended (E) is -40 to +105 °C.

Luminary Micro's LM3S3000 Series of Stellaris ARM Cortex-M3 microcontrollers feature USB 2.0 full-speed (12 Mbps) On-the-Go (OTG) connectivity. The LM3S5000 Series of Stellaris ARM Cortex-M3 microcontrollers add Controller Area Network (CAN) connectivity in conjunction with USB 2.0 full-speed capability. Available in a compact 64-pin LQFP package or feature-rich 100-pin LQFP package, these new Stellaris microcontrollers also contain the popular Stellaris Peripheral Driver Library available on-chip in ROM. As the first ARM Cortex-M3-based microcontrollers with USB OTG connectivity, these new Stellaris microcontrollers offer efficient performance along with extensive integration for a wide range of embedded USB applications.

## Stellaris LM3S3768 USB OTG Evaluation Kit

The Stellaris® LM3S3768 Evaluation Board (EVB) is a compact and versatile evaluation platform for the Stellaris LM3S3768 ARM® Cortex™-M3-based microcontroller. The evaluation board design highlights the LM3S3768 microcontroller's key features including a USB 2.0 full-speed (12 Mbps) On-the-Go (OTG) controller, Analog-to-Digital Converter (ADC), and serial interfaces. The quickstart application that runs out-of-the-box uses four ADC signals paired as two differential channels to implement a 1MS/s oscilloscope application on the LCD display, illustrating high frequency data acquisition and processing with a sophisticated user interface developed using the Stellaris Graphics Library. The quickstart application utilizes the Stellaris USB library to save signal display bitmaps and raw data to the included USB stick and to connect to a PC for remotely controlled data display. The LM3S3768 board also has an In-Circuit Debug Interface (ICDI) that provides hardware debugging not only for the on-board Stellaris device, but also for any Stellaris microcontroller-based target board. In Debug Interface mode, the on-board microcontroller is bypassed, allowing programming or debugging of an external target. The evaluation kits contain all cables, software, and documentation needed to develop and run applications for Stellaris microcontrollers easily and quickly. In addition, example applications demonstrating the use of various third party Real Time Operating Systems and commercial communications stacks are available for download from [www.luminarymicro.com/products/lm3s3768\\_evaluation\\_kit.html](http://www.luminarymicro.com/products/lm3s3768_evaluation_kit.html).



## Stellaris LM3S3768 USB OTG Evaluation Kit Features

- 50 MHz Stellaris LM3S3768 microcontroller with 128 KB Flash and 64 KB SRAM
- 2-channel oscilloscope quickstart application
- USB Host and Device connectors
- Simple setup: USB cable provides serial communication, debugging, and power
- Color LCD graphics display with 128 x 128 pixel resolution
- User LED and navigation switch with press-to-select functionality
- 8-Ohm magnetic speaker with amplifier
- microSD card slot
- USB interface for debugging and power supply
- DC jack for optional 5 V power supply
- Standard ARM® 20-pin JTAG/SWD debug connector with input and output modes
- LM3S3768 microcontroller I/O available on labeled break-out pads
- USB cables (1 each for device and debugger use)
- USB flash memory stick
- Four oscilloscope test leads for quickstart application
- 20-pin JTAG/SWD target cable
- CD containing:
  - Complete documentation
  - Evaluation version of the software tools
  - Quickstart guide and source code
  - Stellaris Peripheral Driver Library and example source code

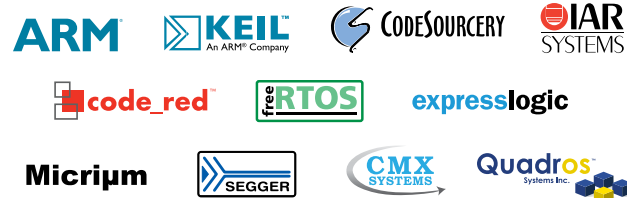

## Evaluation Kit Ordering Information

PART NUMBER	DESCRIPTION
EKK-LM3S3768	Stellaris LM3S3768 USB OTG Evaluation Kit for Keil™ RealView® MDK-ARM (32 KB code-size limited)
EKI-LM3S3768	Stellaris LM3S3768 USB OTG Evaluation Kit for IAR Systems Embedded Workbench® (32 KB code-size limited)
EKC-LM3S3768	Stellaris LM3S3768 USB OTG Evaluation Kit for CodeSourcery G++ GNU (30-day limited)
EKT-LM3S3768	Stellaris LM3S3768 USB OTG Evaluation Kit for Code Red Technologies Red Suite (board-locked)

		LM3S3651	LM3S3759	LM3S3768	LM3S5652	LM3S5662	LM3S5752	LM3S5757	LM3S5762	LM3S5767	LM3S5768	LM3S5769	
MEMORY	Flash (KB)	128	128	128	128	128	128	128	128	128	128	128	
	SRAM (KB)	32	64	64	32	32	64	64	64	64	64	64	
	ROM Software Libraries	✓	✓	✓	✓	✓	✓	✓	✓	✓	✓	✓	
	DMA	✓	✓	✓	✓	✓	✓	✓	✓	✓	✓	✓	
CORE	Max Speed (MHz)	50	50	50	50	50	50	50	50	50	50	50	
	ARM® Cortex™ M3 Core	✓	✓	✓	✓	✓	✓	✓	✓	✓	✓	✓	
	MPU	✓	✓	✓	✓	✓	✓	✓	✓	✓	✓	✓	
	JTAG/SWO/SWD	✓	✓	✓	✓	✓	✓	✓	✓	✓	✓	✓	
TIMERS	System Tick Timer (24-bit)	✓	✓	✓	✓	✓	✓	✓	✓	✓	✓	✓	
	General-Purpose	4	4	4	3	3	3	3	3	3	4	4	
	Real-Time Clock (RTC)	✓	✓	✓	✓	✓	✓	✓	✓	✓	✓	✓	
	Watchdog	✓	✓	✓	✓	✓	✓	✓	✓	✓	✓	✓	
	PWM <sup>[a]</sup>	PWM	–	–	8	–	6	–	–	6	6	8	8
		Dead-Band Generator	–	–	✓	–	✓	–	–	✓	✓	✓	✓
		CCP	8	8	8	6	5	6	3	5	2	8	5
SERIAL INTERFACES	Ethernet (10/100 MAC+PHY)	–	–	–	–	–	–	–	–	–	–	–	
	IEEE1588	–	–	–	–	–	–	–	–	–	–	–	
	CAN MAC	–	–	–	1	1	1	1	1	1	1	2	
	USB	OTG	OTG	OTG	OTG	OTG	OTG	OTG	OTG	OTG	OTG	OTG	
	UART	1	3	2	1	1	1	1	1	1	2	2	
	I <sup>2</sup> C	1	2	2	1	–	1	2	–	1	2	2	
	SSI/SPI	1	2	2	1	1	1	2	1	1	2	2	
	QEI	–	–	1	–	–	–	–	–	–	–	–	1
ANALOG	ADC (10-bit)	ADC Channels	4	8	8	6	4	6	8	4	8	8	
		Precision (LSB)	+/-1	+/-1	+/-1	+/-1	+/-1	+/-1	+/-1	+/-1	+/-1	+/-1	
	ADC Speed (samples per second)	500K	500K	1M	500K	500K	500K	500K	500K	500K	1M	1M	
	Internal Temp Sensor	✓	✓	✓	✓	✓	✓	✓	✓	✓	✓	✓	
Analog Comparators	2	2	2	1	–	1	–	–	–	–	3	2	
GPIOs (5-V TOLERANT) <sup>[b]</sup>	0-33	14-61	1-61	0-33	0-33	0-33	25-61	0-33	0-33	25-61	0-61	0-61	
BATTERY-BACKED HIBERNATION MODULE	✓	✓	✓	✓	✓	✓	✓	✓	✓	✓	–	✓	
BROWN-OUT RESET	✓	✓	✓	✓	✓	✓	✓	✓	✓	✓	✓	✓	
LDO VOLTAGE REGULATOR	✓	✓	✓	✓	✓	✓	✓	✓	✓	✓	✓	✓	
OPERATING TEMPERATURE <sup>[c]</sup>	I	I	I	I	I	I	I	I	I	I	I	I	
PACKAGE	64-LQFP	100-LQFP	100-LQFP	64-LQFP	64-LQFP	64-LQFP	100-LQFP	64-LQFP	100-LQFP	100-LQFP	100-LQFP	100-LQFP	

[a] PWM motion-control functionality can be achieved through dedicated motion control hardware (the PWM pins) or through the motion control features of the general-purpose timers (the CCP pins). See data sheet for details. [b] Minimum is number of pins dedicated to GPIO; additional pins are available if certain peripherals are not used. See data sheet for details. [c] Industrial (I) is -40 to +85 °C and Extended (E) is -40 to +105 °C.



# CAN Connected MCUs

Luminary Micro's LM3S2000 Series of Stellaris ARM Cortex-M3 microcontrollers feature new combinations of industrial connectivity, expanded general purpose I/O, larger on-chip memory, and low-power optimization for battery-backed applications. The Stellaris LM3S2000 series, designed for Controller Area Network (CAN) applications, extends the Stellaris family with Bosch CAN 2.0 A/B networking technology, the golden standard in short-haul industrial networks.

## Stellaris LM3S2965 CAN Evaluation Kit

Stellaris LM3S2965 Evaluation Kits provide a compact and versatile evaluation platform for CAN-enabled Stellaris ARM Cortex-M3-based microcontrollers. With two evaluation boards separately featuring a CAN-enabled LM3S2965 and a CAN-enabled LM3S2110 in the kit, the evaluation kit provides a complete CAN network running right out of the box. The quickstart application demonstrates the transmission and receipt of CAN packets between the two evaluation boards. The LM3S2965 board also has an In-Circuit Debug Interface (ICDI) that provides hardware debugging functionality not only for the on-board Stellaris device, but also for any Stellaris microcontroller-based target board. The evaluation kits contain all cables, software, and documentation needed to develop and run applications for Stellaris microcontrollers easily and quickly. In addition, example applications demonstrating the use of various third party Real Time Operating Systems and commercial CAN stacks are available for download from [www.luminarymicro.com/products/lm3s2965\\_can\\_evaluation\\_kit.html](http://www.luminarymicro.com/products/lm3s2965_can_evaluation_kit.html).



## Stellaris LM3S2965 CAN Evaluation Kit Features

- Fully operational CAN Network-in-a-box, with a quickstart sample application that includes a CAN network and CAN traffic
- LM3S2965 CAN Evaluation Board and separate LM3S2110 CAN Device Board
- Stellaris LM3S2965 and LM3S2110 microcontrollers, each with fully integrated CAN MAC
- Simple setup: USB cable provides serial communication, debugging, and power
- OLED graphics display with 128 x 64 pixel resolution and 16 shades of gray
- User LED, navigation switches, and select pushbuttons
- Magnetic speaker
- All LM3S2965 and LM3S2110 I/O available on labeled break-out pads
- Standard ARM 20-pin JTAG debug connector with input and output modes
- CAN ribbon cable, USB cable, and JTAG cable
- CD containing:
  - Evaluation version of the software tools
  - Quickstart guide and source code
  - Complete documentation
  - Stellaris Peripheral Driver Library and example source code

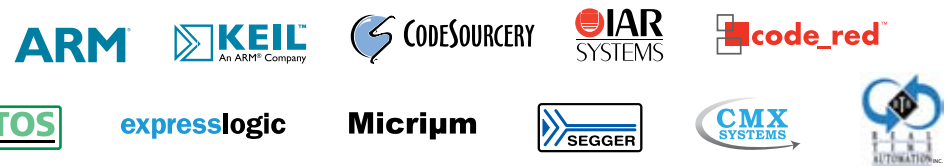

## Evaluation Kit Ordering Information

PART NUMBER	DESCRIPTION
EKK-LM3S2965	Stellaris LM3S2965 CAN Evaluation Kit for Keil RealView MDK-ARM (32 KB code-size limited)
EKI-LM3S2965	Stellaris LM3S2965 CAN Evaluation Kit for IAR Systems Embedded Workbench (32 KB code-size limited)
EKC-LM3S2965	Stellaris LM3S2965 CAN Evaluation Kit for CodeSourcery Sourcery G++ GNU (30-day limited)
EKT-LM3S2965	Stellaris LM3S2965 Evaluation Kit for Code Red Technologies Red Suite (board-locked)

	LM3S2110	LM3S2139		
MEMORY	Flash (KB)	64	64	
	SRAM (KB)	16	16	
	ROM Software Libraries	-	-	
	DMA	-	-	
CORE	Max Speed (MHz)	25	25	
	ARM® Cortex™ M3 Core	✓	✓	
	MPU	✓	✓	
TIMERS	JTAG/SWO/SWD	✓	✓	
	System Tick Timer (24-bit)	✓	✓	
	General-Purpose	3	3	
SERIAL INTERFACES	Real-Time Clock (RTC)	✓	✓	
	Watchdog	✓	✓	
	PWM <sup>[a]</sup>	PWM	2	-
		Dead-Band Generator	✓	-
CCP		4	6	
ANALOG	Ethernet (10/100 MAC+PHY)	-	-	
	IEEE1588	-	-	
	CAN MAC	1	1	
	USB	-	-	
	UART	1	2	
	I²C	1	1	
	SSI/SPI	1	1	
	QEI	-	-	
GPIOs (5-V TOLERANT) <sup>[b]</sup>	ADC Channels	-	4	
	Precision (LSB)	-	+/-1	
	ADC Speed (samples per second)	-	250K	
BATTERY-BACKED HIBERNATION MODULE	Internal Temp Sensor	-	✓	
	Analog Comparators	3	3	
BROWN-OUT RESET	✓	✓		
LDO VOLTAGE REGULATOR	✓	✓		
OPERATING TEMPERATURE <sup>[c]</sup> [d]	I,E	I,E		
PACKAGE	100-LOFP 108-BGA	100-LOFP 108-BGA		

# CAN Connected MCUs

	LM3S2276	LM3S2410	LM3S2412	LM3S2432	LM3S2433	LM3S2601	LM3S2608	LM3S2616	LM3S2620	LM3S2637	LM3S2651	LM3S2671	LM3S2678	LM3S2730	LM3S2739	LM3S2776	LM3S2911	LM3S2918	LM3S2939	LM3S2948	LM3S2950	LM3S2965
Flash (KB)	64	96	96	96	96	128	128	128	128	128	128	128	128	128	128	128	256	256	256	256	256	256
SRAM (KB)	32	32	32	32	64	32	32	16	32	32	32	32	32	64	64	64	64	64	64	64	64	64
ROM Software Libraries	✓	-	-	-	-	-	-	✓	-	-	-	✓	✓	-	-	✓	-	-	-	-	-	-
DMA	✓	-	-	-	-	-	-	✓	-	-	-	✓	✓	-	-	✓	-	-	-	-	-	-
Max Speed (MHz)	50	25	25	50	50	50	50	50	25	50	50	50	50	50	50	50	50	50	50	50	50	50
ARM® Cortex™ M3 Core	✓	✓	✓	✓	✓	✓	✓	✓	✓	✓	✓	✓	✓	✓	✓	✓	✓	✓	✓	✓	✓	✓
MPU	✓	✓	✓	✓	✓	✓	✓	✓	✓	✓	✓	✓	✓	✓	✓	✓	✓	✓	✓	✓	✓	✓
JTAG/SWO/SWD	✓	✓	✓	✓	✓	✓	✓	✓	✓	✓	✓	✓	✓	✓	✓	✓	✓	✓	✓	✓	✓	✓
System Tick Timer (24-bit)	✓	✓	✓	✓	✓	✓	✓	✓	✓	✓	✓	✓	✓	✓	✓	✓	✓	✓	✓	✓	✓	✓
General-Purpose	3	3	3	3	4	4	4	4	4	4	4	4	4	3	3	3	4	4	3	4	4	4
Real-Time Clock (RTC)	✓	✓	✓	✓	✓	✓	✓	✓	✓	✓	✓	✓	✓	✓	✓	✓	✓	✓	✓	✓	✓	✓
Watchdog	✓	✓	✓	✓	✓	✓	✓	✓	✓	✓	✓	✓	✓	✓	✓	✓	✓	✓	✓	✓	✓	✓
PWM <sup>[a]</sup>	PWM	8	-	2	2	6	-	-	6	4	-	4	2	4	-	6	8	-	-	4	-	6
	Dead-Band Generator	✓	-	✓	✓	✓	-	-	✓	✓	-	✓	✓	-	✓	✓	-	-	✓	-	✓	✓
	CCP	1	4	4	4	6	8	8	-	6	6	6	2	2	4	6	1	8	8	4	8	6
Ethernet (10/100 MAC+PHY)	-	-	-	-	-	-	-	-	-	-	-	-	-	-	-	-	-	-	-	-	-	-
IEEE1588	-	-	-	-	-	-	-	-	-	-	-	-	-	-	-	-	-	-	-	-	-	-
CAN MAC	1	1	1	1	1	1	1	1	2	1	1	1	1	1	1	1	1	1	1	2	2	2
USB	-	-	-	-	-	-	-	-	-	-	-	-	-	-	-	-	-	-	-	-	-	-
UART	1	1	2	2	2	3	2	1	1	2	3	1	1	1	2	1	3	2	3	3	3	3
I²C	1	-	1	1	1	2	2	1	1	1	1	1	-	-	1	1	2	2	1	1	1	2
SSI/SPI	1	1	1	1	1	2	2	-	1	1	2	1	1	1	1	2	1	2	1	2	2	2
QEI	-	-	-	-	-	-	-	1	1	-	-	-	1	-	1	-	-	-	1	-	1	2
ADC (10-bit)	ADC Channels	6	-	3	3	3	-	8	6	-	4	4	4	8	-	4	6	-	8	3	8	4
	Precision (LSB)	+/-1	-	+/-1	+/-1	+/-1	-	+/-1	+/-1	-	+/-1	+/-1	+/-1	+/-1	-	+/-1	+/-1	-	+/-1	+/-1	+/-1	+/-1
	ADC Speed (samples per second)	1M	-	250K	250K	250K	-	500K	1M	-	500K	500K	500K	500K	-	500K	1M	-	500K	500K	1M	1M
BATTERY-BACKED HIBERNATION MODULE	Internal Temp Sensor	✓	-	✓	✓	✓	-	✓	✓	-	✓	✓	✓	-	✓	✓	-	✓	✓	✓	✓	✓
	Analog Comparators	-	2	2	2	3	2	2	2	3	3	1	3	-	2	1	-	2	2	3	3	3
GPIOs (5-V TOLERANT) <sup>[b]</sup>	0-33	37-60	20-49	5-34	11-48	21-60	15-52	1-33	12-52	15-46	16-53	3-33	1-33	37-60	20-56	0-33	21-60	15-52	18-57	12-52	10-60	3-56
BROWN-OUT RESET	✓	-	-	-	✓	✓	✓	✓	✓	✓	✓	✓	✓	-	✓	✓	✓	✓	✓	✓	✓	✓
LDO VOLTAGE REGULATOR	✓	✓	✓	✓	✓	✓	✓	✓	✓	✓	✓	✓	✓	✓	✓	✓	✓	✓	✓	✓	✓	✓
OPERATING TEMPERATURE <sup>[c]</sup> [d]	I	I,E	I,E	I,E	I,E	I,E	I,E	I	I,E	I,E	I,E	I	I	I,E	I,E	I	I,E	I,E	I,E	I,E	I,E	I,E
PACKAGE	64-LOFP	100-LOFP 108-BGA	100-LOFP 108-BGA	100-LOFP 108-BGA	100-LOFP 108-BGA	100-LOFP 108-BGA	100-LOFP 108-BGA	64-LOFP	100-LOFP 108-BGA	100-LOFP 108-BGA	100-LOFP 108-BGA	64-LOFP	64-LOFP	100-LOFP 108-BGA	100-LOFP 108-BGA	64-LOFP	100-LOFP 108-BGA	100-LOFP 108-BGA	100-LOFP 108-BGA	100-LOFP 108-BGA	100-LOFP 108-BGA	100-LOFP 108-BGA

[a] PWM motion-control functionality can be achieved through dedicated motion control hardware (the PWM pins) or through the motion control features of the general-purpose timers (the CCP pins). See data sheet for details. [b] Minimum is number of pins dedicated to GPIO; additional pins are available if certain peripherals are not used. See data sheet for details. [c] Industrial (I) is -40 to +85 °C and Extended (E) is -40 to +105 °C. [d] 108-pin BGA and 64-pin LOFP package only available in Industrial temperature.

# Ethernet+CAN Internetworking MCUs

Luminary Micro's LM3S8000 Series of Stellaris ARM Cortex-M3 microcontrollers feature new combinations of industrial connectivity, expanded motion control I/O, larger on-chip memory, and low-power optimization for battery-backed applications. The LM3S8000 series provides the world's first MCUs featuring the combination of a fully-integrated 10/100 Mbps Ethernet solution and Bosch Controller Area Network networking technology with ARM architecture compatibility. The LM3S8000 devices combine up to three CAN 2.0 A/B controllers with both the Ethernet Media Access Control (MAC) and Physical (PHY) layers. In addition, selected LM3S8000 Series Stellaris MCUs also feature hardware assist for IEEE 1588 Precision Time Protocol support.

## Stellaris LM3S8962 Ethernet+CAN Evaluation Kit

Stellaris LM3S8962 Evaluation Kits provide a compact and versatile evaluation platform for simultaneous Ethernet-and-CAN-enabled Stellaris ARM Cortex-M3-based microcontrollers. With two evaluation boards separately featuring an Ethernet+CAN LM3S8962 and a CAN-enabled LM3S2110 in the kit, the evaluation kit provides a complete CAN network running right out of the box. The kit also includes two examples of an embedded web-server demonstration application. The quickstart application that runs out-of-the-box includes an embedded web server utilizing the Open Source lwIP Ethernet stack and also demonstrates the transmission and receipt of CAN packets between the two evaluation boards. The kit also contains a web server application with FreeRTOS.org™ RTOS and the Open Source uIP Ethernet stack. The LM3S8962 board also has an In-Circuit Debug Interface (ICDI) that provides hardware debugging functionality not only for the on-board Stellaris device, but also for any Stellaris microcontroller-based target board. The evaluation kits contain all cables, software, and documentation needed to develop and run applications for Stellaris microcontrollers easily and quickly. In addition, example applications demonstrating the use of various third party Real Time Operating Systems and commercial Ethernet and CAN stacks are available for download from [www.luminarymicro.com/products/lm3s8962\\_ethernet\\_can\\_evaluation\\_kit.html](http://www.luminarymicro.com/products/lm3s8962_ethernet_can_evaluation_kit.html).



## Stellaris LM3S8962 Evaluation Kit Features

- Fully operational Ethernet+CAN Network-in-a-box, with a quickstart sample application that includes simultaneous Ethernet and CAN network traffic
- LM3S8962 Ethernet+CAN Evaluation Board and separate LM3S2110 CAN Device Board
  - Stellaris LM3S8962 microcontroller with fully integrated 10/100 Ethernet (MAC+PHY) and CAN MAC
  - Stellaris LM3S2110 microcontroller with fully integrated CAN MAC
  - Simple setup: USB cable provides serial communication, debugging, and power
  - OLED graphics display with 128 x 64 pixel resolution and 16 shades of gray
  - User LED, navigation switches, and select pushbuttons
  - Magnetic speaker
  - All LM3S8962 and LM3S2110 I/O available on labeled break-out pads
  - Standard ARM 20-pin JTAG debug connector with input and output modes
- Retracting Ethernet cable, CAN ribbon cable, USB cable, and JTAG cable
- CD containing:
  - Evaluation version of the software tools
  - Complete documentation
  - Quickstart guide and source code
  - Stellaris Peripheral Driver Library and example source code



## Evaluation Kit Ordering Information

PART NUMBER	DESCRIPTION
EKK-LM3S8962	Stellaris LM3S8962 Evaluation Kit for Keil RealView MDK-ARM (32 KB code-size limitation)
EKI-LM3S8962	Stellaris LM3S8962 Evaluation Kit for IAR Systems Embedded Workbench (32 KB code-size limited)
EKC-LM3S8962	Stellaris LM3S8962 Evaluation Kit for CodeSourcery G++ GNU (30-day limited)
EKT-LM3S8962	Stellaris LM3S8962 Evaluation kit for Code Red Technologies Red Suite (board-locked)

# Ethernet+CAN Internetworking MCUs

		LM3S8930	LM3S8938	LM3S8930	LM3S8930	LM3S8933	LM3S8938	LM3S8930	LM3S8933	LM3S8938	LM3S8962	LM3S8970	LM3S8971	
MEMORY	Flash (KB)	96	96	128	128	128	128	256	256	256	256	256	256	
	SRAM (KB)	64	64	32	64	64	64	64	64	64	64	64	64	
	ROM Software Libraries	-	-	-	-	-	-	-	-	-	-	-	-	
	DMA	-	-	-	-	-	-	-	-	-	-	-	-	
CORE	Max Speed (MHz)	50	50	50	50	50	50	50	50	50	50	50	50	
	ARM® Cortex™ M3 Core	✓	✓	✓	✓	✓	✓	✓	✓	✓	✓	✓	✓	
	MPU	✓	✓	✓	✓	✓	✓	✓	✓	✓	✓	✓	✓	
	JTAG/SWO/SWD	✓	✓	✓	✓	✓	✓	✓	✓	✓	✓	✓	✓	
TIMERS	System Tick Timer (24-bit)	✓	✓	✓	✓	✓	✓	✓	✓	✓	✓	✓	✓	
	General-Purpose	4	4	4	4	4	4	4	4	4	4	4	4	
	Real-Time Clock (RTC)	✓	✓	✓	✓	✓	✓	✓	✓	✓	✓	✓	✓	
	Watchdog	✓	✓	✓	✓	✓	✓	✓	✓	✓	✓	✓	✓	
PWM[a]	PWM	-	-	-	-	-	-	-	-	-	6	-	6	
	Dead-Band Generator	-	-	-	-	-	-	-	-	-	✓	-	✓	
	CCP	2	4	2	2	4	6	2	4	6	2	2	6	
SERIAL INTERFACES	Ethernet (10/100 MAC+PHY)	✓	✓	✓	✓	✓	✓	✓	✓	✓	✓	✓	✓	
	IEEE1588	-	✓	-	✓	-	-	-	✓	✓	✓	✓	-	
	CAN MAC	3	1	1	1	1	1	2	1	1	1	3	1	
	USB	-	-	-	-	-	-	-	-	-	-	-	-	
	UART	1	2	2	2	2	3	1	2	3	2	2	1	
	I <sup>2</sup> C	1	1	1	1	1	1	1	1	2	1	1	-	
	SSI/SPI	2	1	1	1	1	2	1	1	1	1	2	1	
ANALOG	QEI	-	-	-	-	-	-	-	-	-	2	-	1	
	ADC (10-bit)	ADC Channels	-	8	-	-	4	8	-	4	8	4	-	8
		Precision (LSB)	-	+/-1	-	-	+/-1	+/-1	-	+/-1	+/-1	+/-1	-	+/-1
		ADC Speed (samples per second)	-	1M	-	-	500K	500K	-	1M	1M	500K	-	1M
Internal Temp Sensor	-	✓	-	-	✓	✓	-	✓	✓	✓	-	✓		
Analog Comparators	-	3	-	-	3	1	-	3	3	1	-	1		
GPIOs (5-V TOLERANT)[b]	8-35	7-36	10-31	11-32	5-35	4-38	13-34	6-36	3-38	5-42	17-46	4-38		
BATTERY-BACKED HIBERNATION MODULE	-	-	✓	✓	✓	✓	✓	✓	✓	✓	✓	✓		
BROWN-OUT RESET	✓	✓	✓	✓	✓	✓	✓	✓	✓	✓	✓	✓		
LDO VOLTAGE REGULATOR	✓	✓	✓	✓	✓	✓	✓	✓	✓	✓	✓	✓		
OPERATING TEMPERATURE[c][d]	I,E	I,E	I,E	I,E	I,E	I,E	I,E	I,E	I,E	I,E	I,E	I,E		
PACKAGE	100-LQFP 108-BGA	100-LQFP 108-BGA	100-LQFP 108-BGA	100-LQFP 108-BGA	100-LQFP 108-BGA	100-LQFP 108-BGA	100-LQFP 108-BGA	100-LQFP 108-BGA	100-LQFP 108-BGA	100-LQFP 108-BGA	100-LQFP 108-BGA	100-LQFP 108-BGA	100-LQFP 108-BGA	

[a] PWM motion-control functionality can be achieved through dedicated motion control hardware (the PWM pins) or through the motion control features of the general-purpose timers (the CCP pins). See data sheet for details. [b] Minimum is number of pins dedicated to GPIO; additional pins are available if certain peripherals are not used. See data sheet for details. [c] Industrial (I) is -40 to +85 °C and Extended (E) is -40 to +105 °C. [d] 108-pin BGA only available in Industrial temperature.



# Intelligent Display Module Reference Design Kit

The Luminary Micro Stellaris® Intelligent Display Reference Design Kit (RDK-IDM) offers a complete, open-tooled Ethernet-connected graphical touch-screen user interface design solution. The kit contains all the necessary hardware and software for you to design, develop, and integrate your Intelligent Display Module into industrial control, automation, and instrumentation applications. Featuring the option of Power-over-Ethernet (PoE) or DC power input, the Stellaris® Intelligent Display Module Reference Design Kit offers a simple method to produce intelligent terminals that can be simultaneously powered and network-connected by a single CAT5 Ethernet cable. The design also features additional serial connectivity options for easy implementation as a Human Machine Interface (HMI) touch display panel in an embedded control device. The RDK-IDM is the first display module design available with the efficient performance and robust integration of an ARM® Cortex™-M3 microcontroller, positioning the design into building access controllers and security systems, intelligent white goods and home appliances, thin clients, and factory automation applications.

## Features

At the heart of the Stellaris Intelligent Display Module Reference Design is a highly-integrated 32-bit LM3S6918 ARM Cortex-M3 Stellaris microcontroller featuring 10/100 Ethernet MAC and PHY integrated on-chip. With the ARM architecture, you have access to the world's most extensive ecosystem for development tools, applications, training and support, operating systems, and software stacks. Customized development of software for the RDK-IDM is simplified with Luminary Micro's comprehensive Stellaris Graphics Library and ARM development tools from trusted tools partners.

The RDK-IDM includes the following product features:

- Bright QVGA LCD touch-screen display
  - 16-bit color, 2.8" QVGA 240 x 320 pixels
  - White LED backlight with resistive touch panel
- Ethernet and serial connectivity options
  - 10/100 Ethernet with Auto MDI/MDIX and Traffic/Link indicator LED
  - Header provides TXD and RXD signals
  - RS232 signal levels
- High performance 50 MHz LM3S6918 microcontroller with 256 KB on-chip flash and 64 KB on-chip SRAM
- Flexible interfaces and terminal block connections
  - microSD slot
  - Relay output
  - Four ADC terminal block inputs
- Flexible power supply options
  - Power over Ethernet (IEEE 802.3af compliant)
  - 24 V DC power jack, 5 V DC terminals
- Easy to customize
  - Includes full source code and design files
  - Includes complete example applications
  - Develop using tools from Keil, IAR, Code Sourcery, and Code Red Technologies
  - Supported by Stellaris Graphics Library and Stellaris Peripheral Driver Library

## Kit Contents

The Stellaris Intelligent Display Module is offered in as a reference design and development kit (RDK-IDM) as well as a stand-alone, ready-for-production module (MDL-IDM with Power-over-Ethernet or MDL-IDM28 with Ethernet). The reference design and development kit ships with everything needed to quickly evaluate and easily customize the Intelligent Display Module for your specific application, including:

- Stellaris® Intelligent Display Module (MDL-IDM with metal standoffs)
- 24 V power supply with international plug adapters
- Retractable Ethernet cable
- Debug adapter
- Quickstart Guide, User's Manual, Software Reference Manual, Board Data Sheet, software source code, BOM, schematics, and Gerber files on CD

## Ordering Information

PART NUMBER	DESCRIPTION
RDK-IDM	Stellaris Ethernet-Enabled Intelligent Display Module Reference Design Kit (RDK)
MDL-IDM	Stellaris Intelligent Display Module with Power-over-Ethernet for Single-Unit Packaging
MDL-IDM-B	Stellaris Intelligent Display Module with Power-over-Ethernet for Volume Packaging
MDL-IDM28	Stellaris Ethernet-Enabled Intelligent Display Module for Single-Unit Packaging
MDL-IDM28-B	Stellaris Ethernet-Enabled Intelligent Display Module for Volume Packaging



Stellaris Intelligent Display Module Reference Design Kit



Stellaris Intelligent Display Module

# Intelligent Display Module with 3.5" Landscape Display Reference Design Kit

Luminary Micro's Stellaris® Intelligent Display Module with 3.5" Landscape Display (MDL-IDM-L35) offers a complete QVGA touch-screen user interface for control, automation, and instrumentation applications. The MDL-IDM-L35 features several serial, digital, and analog connectivity options for easy implementation as a Human Machine Interface (HMI) touch display panel in an embedded control device. Software development for the RDK-IDM-L35 is simplified by using Luminary Micro's comprehensive graphics library and ARM development tools from ARM tools partners. Stellaris® IDMs are the first display modules available with the efficient performance and robust integration of an ARM® Cortex™-M3 microcontroller, positioning the modules for use in building access controllers and security systems, intelligent white goods and home appliances, thin clients, and factory automation applications.

## Features

The MDL-IDM-L35 ships as a software-customizable module with the following features:

- Bright QVGA LCD touch-screen display
  - 262 K colors, 3.5" QVGA 320 x 240 pixels
  - White LED backlight with resistive touch panel
- Serial connectivity options
  - RS232 serial port with RS232 signal levels
  - UART serial port with TTL signal levels
- High performance Stellaris LM3S1958 microcontroller and large memory
  - 50 MHz 32-bit ARM® Cortex™-M3 core
  - 256 KB main flash memory, 64 KB SRAM
- MicroSD card slot
- 5 V power supply with DC regulator that generates 3.3 V for powering the board
- Easy to customize
  - Includes full source code, example applications, and design files
  - Develop using tools supporting the IDM-L35 from Keil, IAR, Code Sourcery, and Code Red (using a Stellaris evaluation kit or preferred ARM Cortex-M3 debugger)
  - Supported by Stellaris® Graphics Library and Stellaris® Peripheral Driver Library

## Kit Contents

The Stellaris Intelligent Display Module is offered in as a reference design and development kit (RDK-IDM-L35) as well as a stand-alone, ready-for-production module (MDL-IDM-L35). The reference design and development kit ships with everything needed to quickly evaluate and easily customize the Intelligent Display Module for your specific application, including:

- Stellaris Intelligent QVGA 3.5" Touch Panel Module (MDL-IDM-L35) with metal standoffs
- USB to TTL serial cable to simultaneously power the board and connect to the LM3S1958 Stellaris microcontroller via UART0
- JTAG debug adapter for 10-pin fine-pitch connection to a standard 20-pin connector
- 24 V power supply with international plug adapters
- Quickstart Guide, User's Manual, Software Reference Manual, Board Data Sheet, source code, BOM, schematics, and Gerber files on CD



Stellaris Intelligent Display Module with 3.5" Landscape Display



Stellaris Intelligent Display Module with 3.5" Landscape Display

## Ordering Information

PART NUMBER	DESCRIPTION
RDK-IDM-L35	Stellaris Intelligent Display Module with 3.5" Landscape Display Reference Design Kit (RDK)
MDL-IDM-L35	Stellaris Intelligent Display Module with 3.5" Landscape Display for Single-Unit Packaging
MDL-IDM-L35-B	Stellaris Intelligent Display Module with 3.5" Landscape Display for Volume Packaging

# Serial-to-Ethernet Reference Design Kit

The Luminary Micro Stellaris® Serial-to-Ethernet Reference Design Kit (RDK-S2E) offers a complete, open-tooled, and ready-to-implement solution designed to add Internet connectivity to any serial device. The kit contains all the necessary hardware and software for you to design, develop, and integrate your serial-to-Ethernet design into industrial applications. The most common application for the RDK-S2E is for augmenting legacy products that contain a serial port for a configuration or control interface. In addition, newer computers, especially laptop computers, do not necessarily have serial ports, and a serial connection is limited by cable length (typically 10 m). Implementing a Stellaris® Serial-to-Ethernet design into the legacy serial device provides many benefits including no major board redesign or software changes, easy sharing on a network other than Ethernet, tiny form-factor for unobtrusive implementation, and 10-meter maximum cable length for serial connections is no longer a limitation.

## Features

The RDK-S2E is the first Serial-to-Ethernet converter design available with the efficient performance and robust integration of an ARM Cortex-M3 microcontroller. At the heart of the Stellaris Serial-to-Ethernet design is a highly-integrated 32-bit Stellaris LM3S6432 ARM Cortex-M3 microcontroller with 50 MHz of performance and ample single-cycle on-chip Flash and SRAM memory to handle efficient network trafficking. For maximum space savings, the Stellaris microcontroller is offered in a small BGA package and integrates the 10/100 Ethernet MAC and PHY on-chip. With ARM, you have access to the world's most extensive ecosystem for development tools, applications, training and support, operating systems, and software stacks.

The RDK-S2E includes the following product features:

- Stellaris® LM3S6432 ARM® Cortex™-M3 microcontroller in a 10 x 10 mm BGA package for reduced board size
- 10/100 Mbit Ethernet port
  - Auto MDI/MDIX cross-over correction
  - Traffic and link indicators
- 2 UART ports include RTS/CTS for flow control
  - UART0 has RS232 levels, transceiver runs at up to 250 Kbits/sec
  - UART1 has CMOS/TTL levels, can run at 1.5 Mbits/sec
- Software
  - IP configuration with static IP address or DHCP
  - Telnet server for access to serial port
  - Web server for module configuration
  - UDP responder for device discovery
  - Telnet client for Ethernet-based serial port extender
  - SSH server for secure communications
- Module supports 5 V and 3.3 V supplies
- Multiple mounting options including optional mounting bracket
- JTAG port pads for factory programming

## Kit Contents

The Stellaris® Serial-to-Ethernet Module is offered as a reference design kit (RDK-S2E) as well as a stand-alone, ready-for-production module (MDL-S2E). The RDK ships with everything needed to quickly evaluate and easily customize the MDL-S2E for your specific application, including:

- Stellaris® Serial-to-Ethernet Module (MDL-S2E)
- RS-232 adaptor board
- Retractable Ethernet cable
- DB9 serial cable
- USB cable
- Quickstart Guide, User's Manual, Software Reference Manual, Board Data Sheet, software source code, BOM, schematics, and Gerber files on CD



Stellaris Serial-to-Ethernet Reference Design Kit



Stellaris Serial-to-Ethernet Module

## Ordering Information

PART NUMBER	DESCRIPTION
RDK-S2E	Stellaris Serial-to-Ethernet Reference Design Kit (RDK)
MDL-S2E	Stellaris Serial-to-Ethernet Module for Single-Unit Packaging
MDL-S2E-B	Stellaris Serial-to-Ethernet Module for Volume Packaging

# Stepper Motor Reference Design Kit

The Luminary Micro Stellaris Stepper Motor Control Reference Design Kit (RDK-Stepper) contains all the necessary hardware and software for you to design, develop, and integrate state-of-the-art stepper motor applications. The RDK-Stepper combines the strength and flexibility of Luminary Micro's Stellaris microcontrollers with Fairchild Semiconductor's gate drivers and MOSFETs to create an advanced stepper motor control design that has been carefully engineered for performance, cost, and flexibility. Stepper motors are particularly suited for use in two- and three-axis CNC equipment, sorting and grading equipment, specialized printers and scanners, and factory automation.

The kit's software architecture is directly scalable from micro-horsepower applications to the largest current stepper designs. Structured as prioritized Interrupt Service Routines (ISRs), this powerful and flexible software architecture runs efficiently in the background, leaving significant headroom for system application and/or networking tasks.

## Features

The RDK-Stepper contains Luminary Micro's feature-rich Stellaris LM3S617 microcontroller designed for motion control applications, a Fairchild Semiconductor power stage consisting of Fairchild's FAN7382 HVIC Driver and FDMS3672 MOSFET, a NEMA23 stepper motor, a graphical control program for Windows™, and accompanying cables, source code, and documentation. The Stepper RDK takes advantage of the integrated features of the Stellaris microcontroller and the processing power of the ARM Cortex-M3 core to implement chopper control without the need for an external step controller or comparator circuits. The graphical control program allows users to experiment with varying drive parameters and observe the effect on motor performance.

The Stepper RDK includes the following product features:

- Advanced chopper control of bipolar stepper motors
- Software-based chopper control to operate high-torque steppers at high step rates
- Fast and slow decay modes
- Full step, half step and micro step modes with missed-step detection
- High step rates up to 10,000 steps/sec
- Programmable holding current
- Integrated USB virtual COM port
- Support for external debugger through standard 20-pin ARM header
- Easy power and motor connection through pluggable terminal blocks
- Bootloader for firmware upgrades over serial port

## Kit Contents

The Stepper RDK ships with everything needed to evaluate bipolar stepper motor control including:

- Main control circuit board
- NEMA23 stepper motor
- 24 V wall power supply with international plug kit
- USB cable
- Graphical control program for Windows on CD
- Quickstart Guide, User's Manual, Software Reference Manual, source code, BOM, schematics, and Gerber files on CD



Stellaris Stepper Motor Reference Design Kit

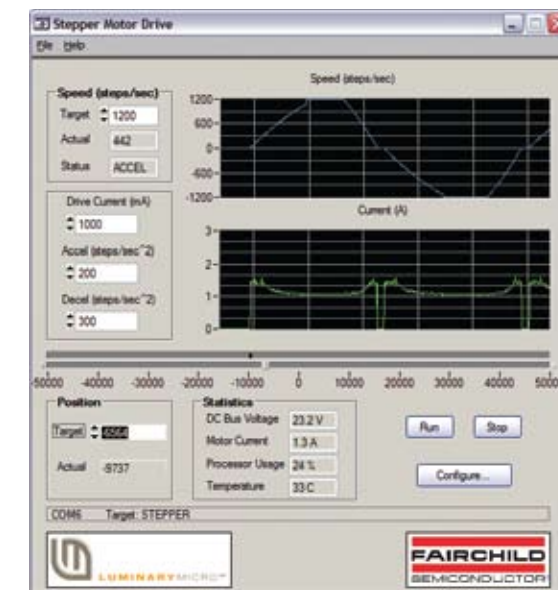

RDK-Stepper Windows Graphical Control Program Screen Shot

## Ordering Information

PART NUMBER	DESCRIPTION
RDK-Stepper	Stellaris Stepper Motor Reference Design Kit
MDL-Stepper	Stellaris Stepper Motor Control Board Only Single-Unit Packaging
MDL-Stepper-B	Stellaris Stepper Motor Central Board Only Volume Packaging



# Brushless DC Reference Design Kit

The Luminary Micro Stellaris Brushless DC (BLDC) Motor Control Reference Design Kit (RDK-BLDC) with Ethernet and CAN contains all the necessary hardware and software for you to design, develop, and integrate your BLDC motor applications in industrial networks. The RDK-BLDC combines the strength and flexibility of Luminary Micro's Stellaris microcontrollers with Fairchild Semiconductor's power modules to deliver a sophisticated four-quadrant motor control for three-phase brushless DC motors rated at up to 36 V. Brushless DC motors are particularly suited for use in factory automation, robotics, electric wheelchairs and mobility devices, pumping and ventilation systems, and small appliances.

## Features

The RDK-BLDC contains Luminary Micro's feature-rich Stellaris LM3S8971 microcontroller with Ethernet and CAN, a three-phase brushless DC motor, a graphical control program for Windows™, and accompanying cables, source code, and documentation. The RDK-BLDC takes advantage of the integrated motion and communications features of the Stellaris LM3S8971 microcontroller and the processing power of the ARM® Cortex™-M3 core to optimally control a wide range of brushless DC motors in diverse applications. The graphical control program allows you to experiment with varying drive parameters and observe the effect on motor performance.

### The RDK-BLDC includes the following product features:

- 10/100 Ethernet and CAN communications interfaces
- Advanced motor control for three-phase brushless DC motors
- Four quadrant operation for precise motion control
- Hall Effect, Quadrature, and Sensorless operation modes
- Controls 3-phase BLDC motors up to 36 V 500 W
- Easy to customize – full source code and design files available
- Interrupt-driven motion software, easily extendable
- 30 MIPS headroom for system software
- On-board braking circuit
- Incremental quadrature encoder input
- Analog and digital control inputs
- Test mode push-button
- Status LEDs indicate Power, Run, and Fault conditions
- Optional power-managed fan for forced-air cooling
- Screw terminals for all power and signal wiring
- JTAG/SWD port for software debugging

## Kit Contents

The RDK-BLDC ships with everything needed to evaluate brushless DC motor control including:

- Main control circuit board
- 3-phase brushless DC motor
- 24 V power supply
- Retractable Ethernet cable
- Debug adapter
- Graphical control program for Windows on CD
- Quickstart Guide, User's Manual, Software Reference Manual, Board Data Sheet, source code, BOM, schematics, and Gerber files on CD



Stellaris Brushless DC Motor Reference Design Kit

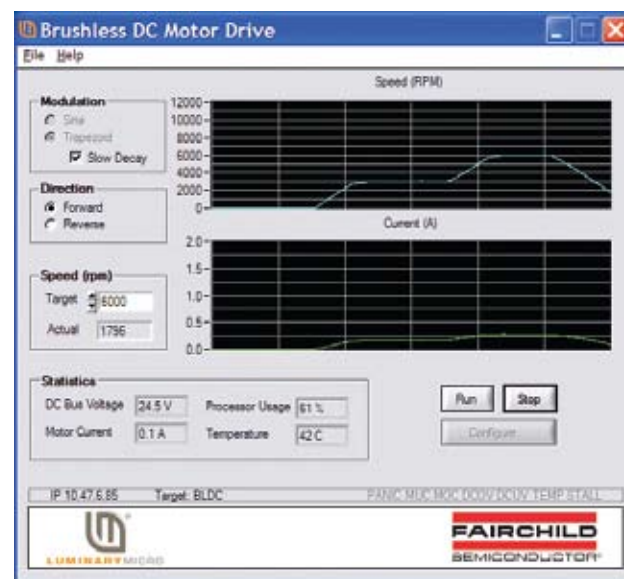

RDK-BLDC Windows Graphical Control Program Screen Shot

## Ordering Information

PART NUMBER	DESCRIPTION
RDK-BLDC	Stellaris Brushless DC Motor Control Reference Design Kit
MDL-BLDC	Stellaris Brushless DC Motor Control Board Only Single-Unit Packaging
MDL-BLDC-B	Stellaris Brushless DC Motor Control Board Only Volume Packaging

# Brushed DC Motor Control with CAN Reference Design Kit

Luminary Micro's Stellaris® Brushed DC Motor Control Reference Design Kit (RDK-BDC) with CAN contains all the necessary hardware and software for you to design, develop, and integrate your brushed DC motor applications in industrial networks. The Brushed DC motor control design offers high performance CAN networking with variable speed control for 12 V brushed DC motors at up to 40 A continuous current, along with a rich set of control options and sensor interfaces, including analog and quadrature encoder interfaces.

The design uses highly optimized software and a powerful 32-bit Stellaris LM3S2616 microcontroller to implement open-loop speed control as well as closed-loop control of speed, position, or motor current.

The motor control design is powered by the Stellaris LM3S2616 microcontroller, featuring Controller Area Network and advanced motion control capabilities. The high-frequency Stellaris-based PWM enables DC motors to run smoothly and quietly over a wide speed range. The LM3S2616 microcontroller's robust combination of features, along with the efficient and deterministic performance of the ARM Cortex-M3 core, positions the design into a wide variety of consumer and industrial applications, including factory automation devices and systems, mobile robots, household appliances, pumping and ventilation systems, and electric wheelchairs and mobility devices.

Most users will use the supplied software as-is for brushed DC motor control applications. For other users, software development for the RDK-BDC is simplified by using Luminary Micro's comprehensive Stellaris peripheral driver library and ARM development tools from our tools partners.



Stellaris Brushed DC Motor Control with CAN Reference Design Kit

## Features

### The MDL-BDC ships as a ready-to-run, yet software-customizable module with the following features:

- Quiet control of brushed DC motors
  - 15 kHz PWM frequency
- Two options for Speed control
  - Industry-standard R-C servo type (PWM) interface
  - Controller Area Network (CAN) interface
- CAN communication
  - Full configurability of module options
  - Real-time monitoring of current, voltage, speed, and speed
  - Load firmware over CAN
- Status LED indicates Run, Direction, and Fault Conditions
- Motor brake/coast selector
- Limit switch inputs for forward and reverse directions
- Quadrature encoder input (QE1) and Analog input
- Colored screw terminals for all power wiring
  - Headers (0.1 inch pitch) for all control signals
- Easy to customize
  - Includes full source code, example applications, and design files
  - Develop using tools from Keil, IAR, Code Sourcery, or Code Red (using a Stellaris evaluation kit or preferred ARM Cortex-M3 debugger)
  - Supported by Stellaris Peripheral Driver Library

## Kit Contents

In addition to being offered as a stand-alone, ready-for-production module (MDL-BDC), the Stellaris MDL-BDC is also offered as a complete open-tool reference design kit (RDK-BDC). The RDK ships with everything needed to quickly evaluate and easily customize the MDL-BDC for your specific application, including:

- MDL-BDC motor control module
- Mabuchi RS-555PH3255 Brushed DC Motor (rated 5000 RPM, 12 V, 3 A)
- Universal input wall power supply
- BDC CAN console based on EK-LM3S2965 Evaluation Kit
- CAN cable and terminator; USB cable; ARM JTAG/SWD ribbon cable
- JTAG debug adapter for 10-pin fine-pitch connection to a standard 20-pin connector
- Quickstart Guide, User's Manual, Software Reference Manual, Board Data Sheet, source code, BOM, schematics, and Gerber files on CD

## Ordering Information

PART NUMBER	DESCRIPTION
RDK-BDC	Stellaris Brushed DC Motor Control with CAN Reference Design Kit (RDK)
MDL-BDC	Stellaris Brushed DC Motor Control with CAN Module Single-Unit Packaging
MDL-BDC-B	Stellaris Brushed DC Motor Control with CAN Module Volume Packaging

# AC Induction Motor Reference Design Kit

The Luminary Micro Stellaris AC Induction Motor Reference Design Kit (RDK-ACIM) contains all the necessary hardware and software for you to design, develop, and integrate state-of-the-art AC induction motor applications. The ACIM design combines the strength and flexibility of Luminary Micro's Stellaris microcontrollers with Fairchild Semiconductor's power modules to create an advanced variable speed AC motor control design that has been carefully engineered for performance, cost, and flexibility. AC induction motors are particularly suited for use in major home appliances (refrigerators, dishwashers, washing machines, and dryers), residential and light commercial HVAC systems, and three-phase industrial motor drives.

The kit's software architecture is directly scalable from fractional-horsepower applications to those in the hundreds of kilowatts of power. Structured as prioritized Interrupt Service Routines (ISRs), this powerful and flexible software architecture runs efficiently in the background, leaving significant headroom for system application and/or networking tasks.

## Features

The RDK-ACIM contains Luminary Micro's feature-rich Stellaris LM3S818 microcontroller designed for motion control applications, Fairchild Semiconductor's FSBS10CH60 power module, a Selni three-phase appliance AC motor, a graphical control program for Windows™, and accompanying cables, source code, schematics, BOM, and documentation. The RDK-ACIM takes advantage of the integrated features and processing power of the Stellaris microcontroller to implement energy-efficient, modern control algorithms including Space Vector Modulation (SVM). The graphical control program allows users to experiment with varying drive parameters and observe the effect on motor performance.

The RDK-ACIM includes the following product features:

- Advanced motor control for three-phase and single-phase AC induction motors
- Active braking circuit
- Active in-rush control circuit
- Optional control of external Power Factor Correction (PFC) stage
- Easily change line filter, bus capacitors, and JTAG interface
- Includes code for main control algorithms including space-vector modulation and sine control
- Accurate current sensing through split low-side current sensing
- Several isolated control input options including:
  - Virtual COM port using integrated USB port
  - Windows GUI application for configuration, control, and monitoring
  - Logic-level serial port
  - Speed potentiometer and mode switch
  - Speed and position monitoring through quadrature encoder/tachometer input
- Electrically isolated JTAG port for software debugging
- Bootloader for firmware upgrades over serial port



Stellaris AC Induction Motor Reference Design Kit

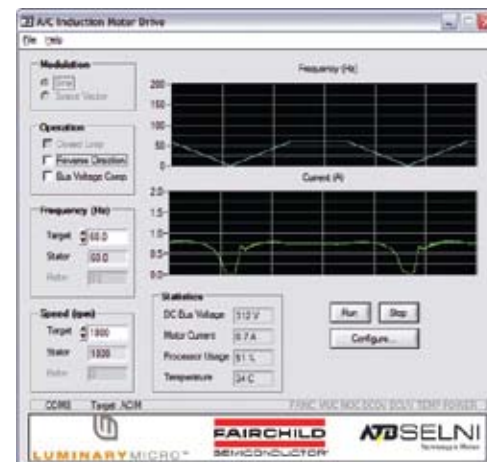

RDK-ACIM Windows Graphical Control Program Screen Shot

## Kit Contents

The RDK-ACIM ships with everything needed to evaluate AC induction motor control including:

- Main control circuit board with a factory-installed heat sink
- 3-phase appliance AC motor (0-20000 rpm)
- Power cables
- USB cable
- Graphical control program for Windows on CD
- Quickstart Guide, User's Manual, Software Reference Manual, source code, BOM, schematics, and Gerber files on CD
- Bootloader for firmware upgrades over serial port

## Ordering Information

PART NUMBER	DESCRIPTION
RDK-ACIM	Stellaris AC Induction Motor Reference Design Kit
MDL-ACIM	Stellaris AC Induction Motor Control Board Only Single-Unit Packaging
MDL-ACIM-B	Stellaris AC Induction Motor Only Control Board Volume Packaging



## contact us

LUMINARY MICRO INC.  
108 WILD BASIN , SUITE 350  
AUSTIN, TX 78746  
MAIN: +1-512-279-8800  
FAX: +1-512-279-8879

<http://www.luminarymicro.com>  
[sales@luminarymicro.com](mailto:sales@luminarymicro.com)

TECHNICAL SUPPORT:  
[www.luminarymicro.com/support](http://www.luminarymicro.com/support)  
or [support@luminarymicro.com](mailto:support@luminarymicro.com)





**LUMINARY** MICRO

COPYRIGHT © 2008 Luminary Micro, Inc. All rights reserved.

Stellaris and the Luminary Micro logo are registered trademarks of Luminary Micro, Inc. or its subsidiaries in the United States and other countries.

ARM and Thumb are registered trademarks, and Cortex is a trademark of ARM Limited.

Other names and brands may be claimed as the property of others.