

ATMEL Norway AS Vestre Rosten 79 N-7075 TILLER Norway		<b>ATMEL</b>
Title AT32STK1000 - Top level 1		
Size A3	Document Number T0241	Rev B1
Date: Tuesday, September 26, 2006	Sheet 1	of 18

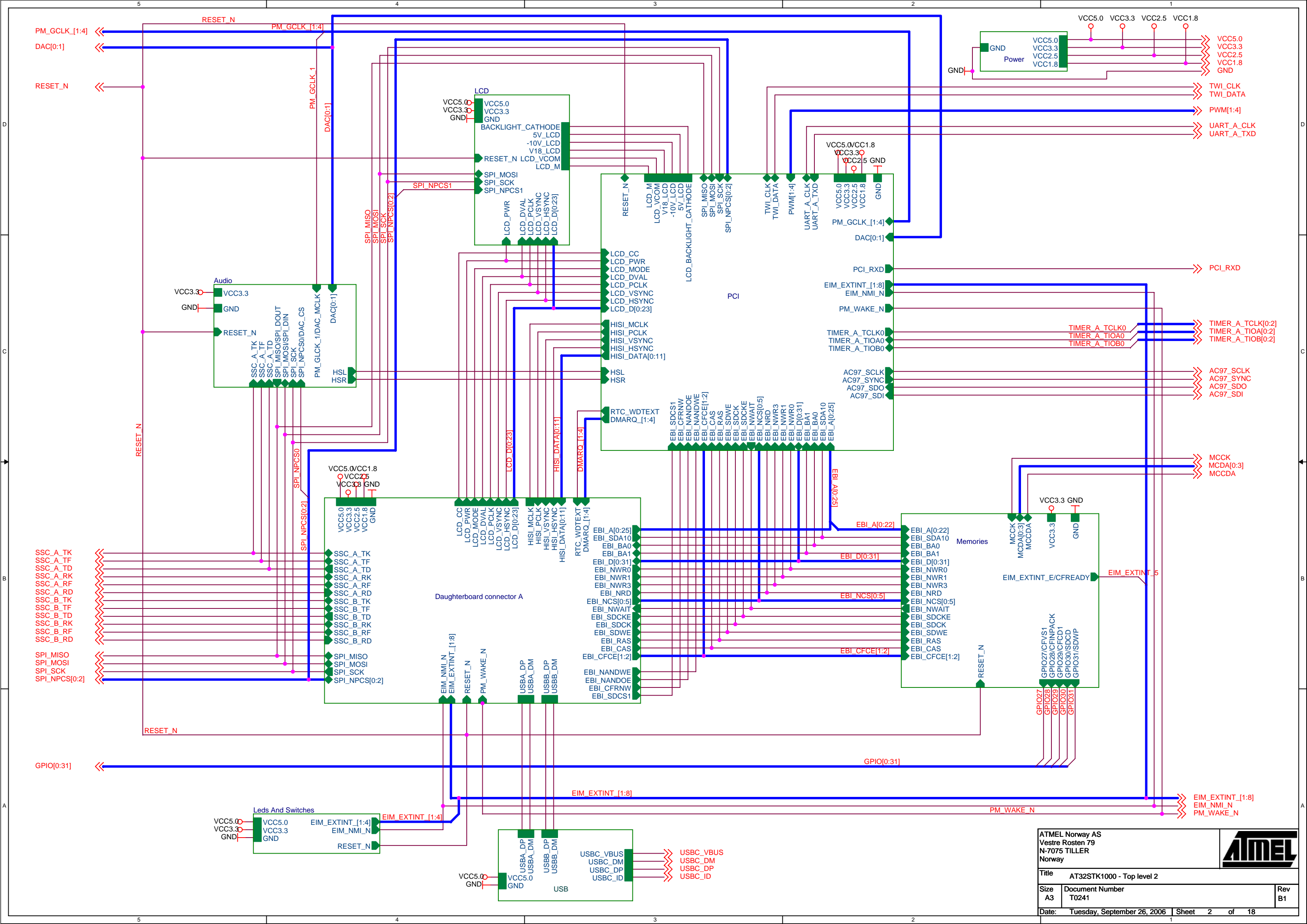

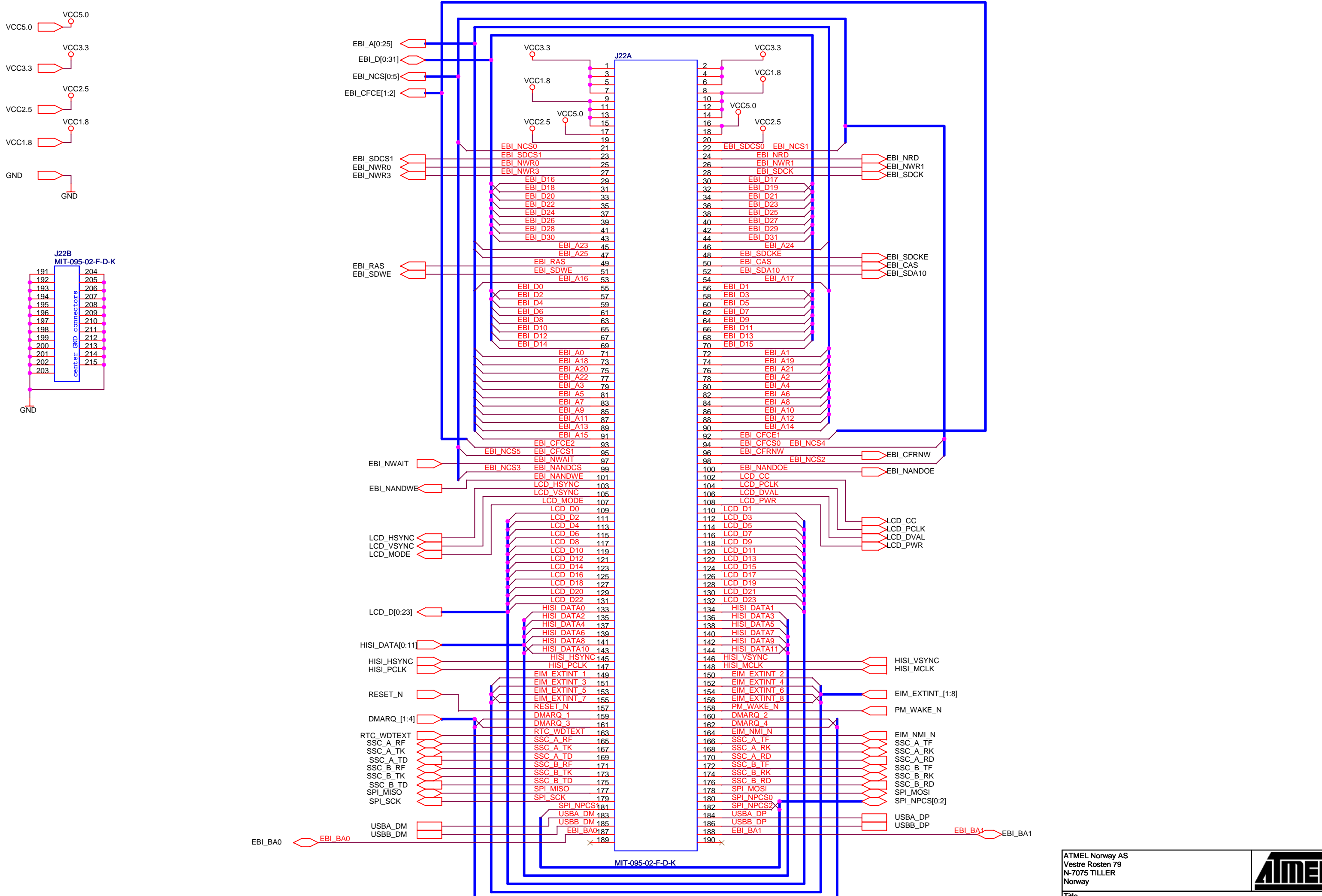

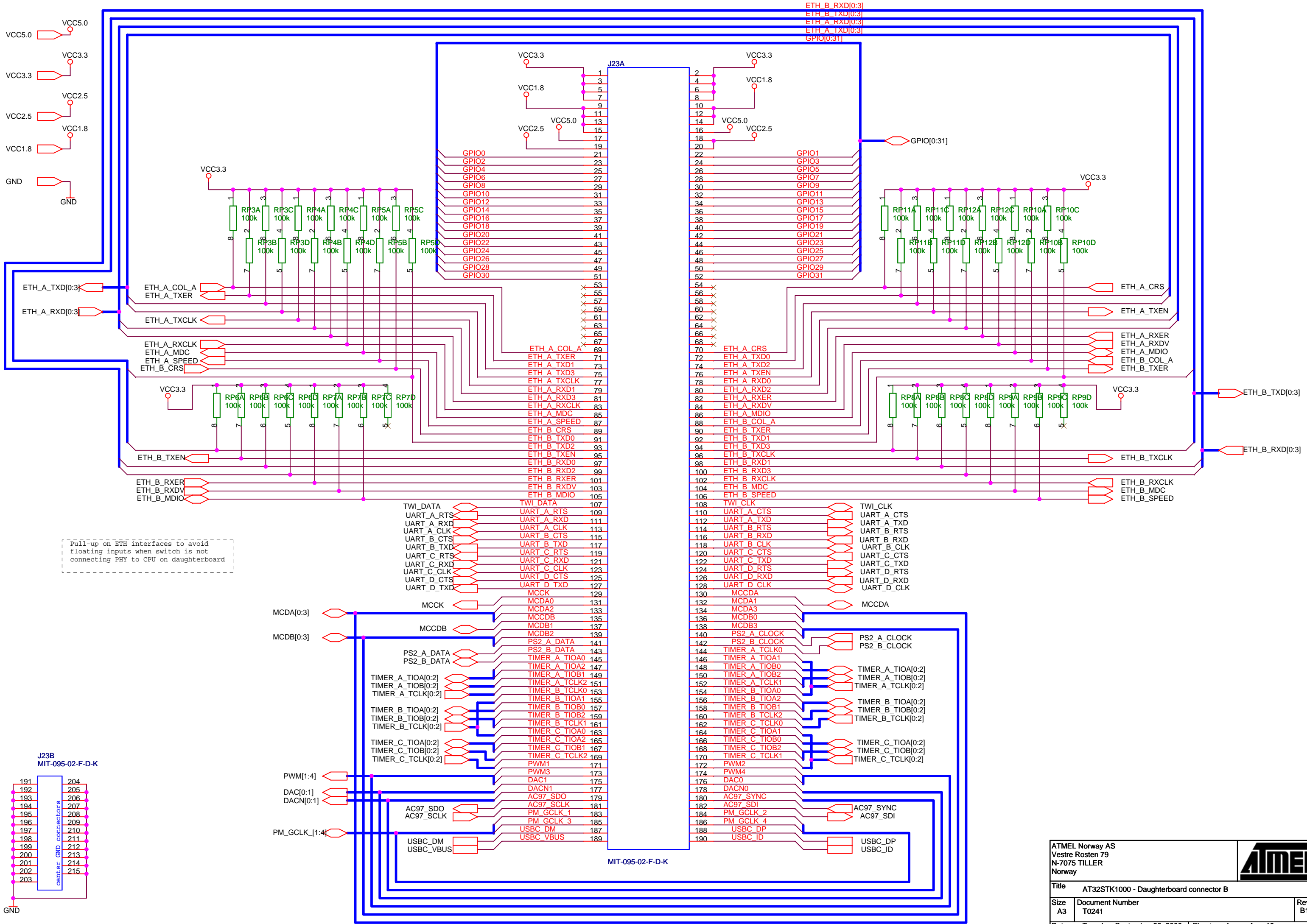

Pull-up on ETH interfaces to avoid floating inputs when switch is not connecting PHY to CPU on daughterboard

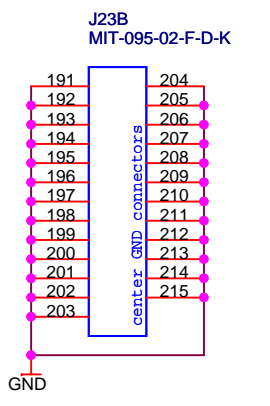

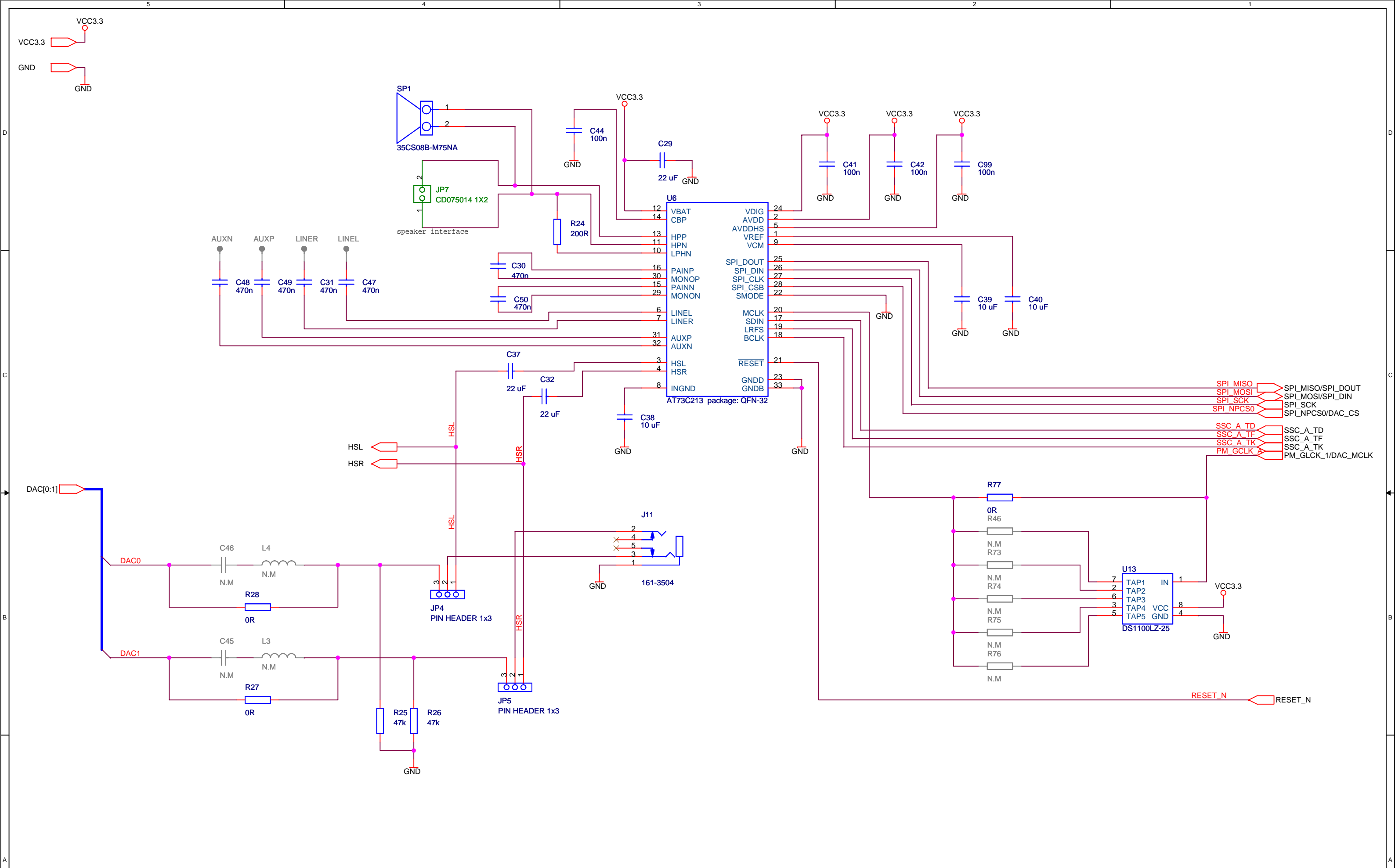

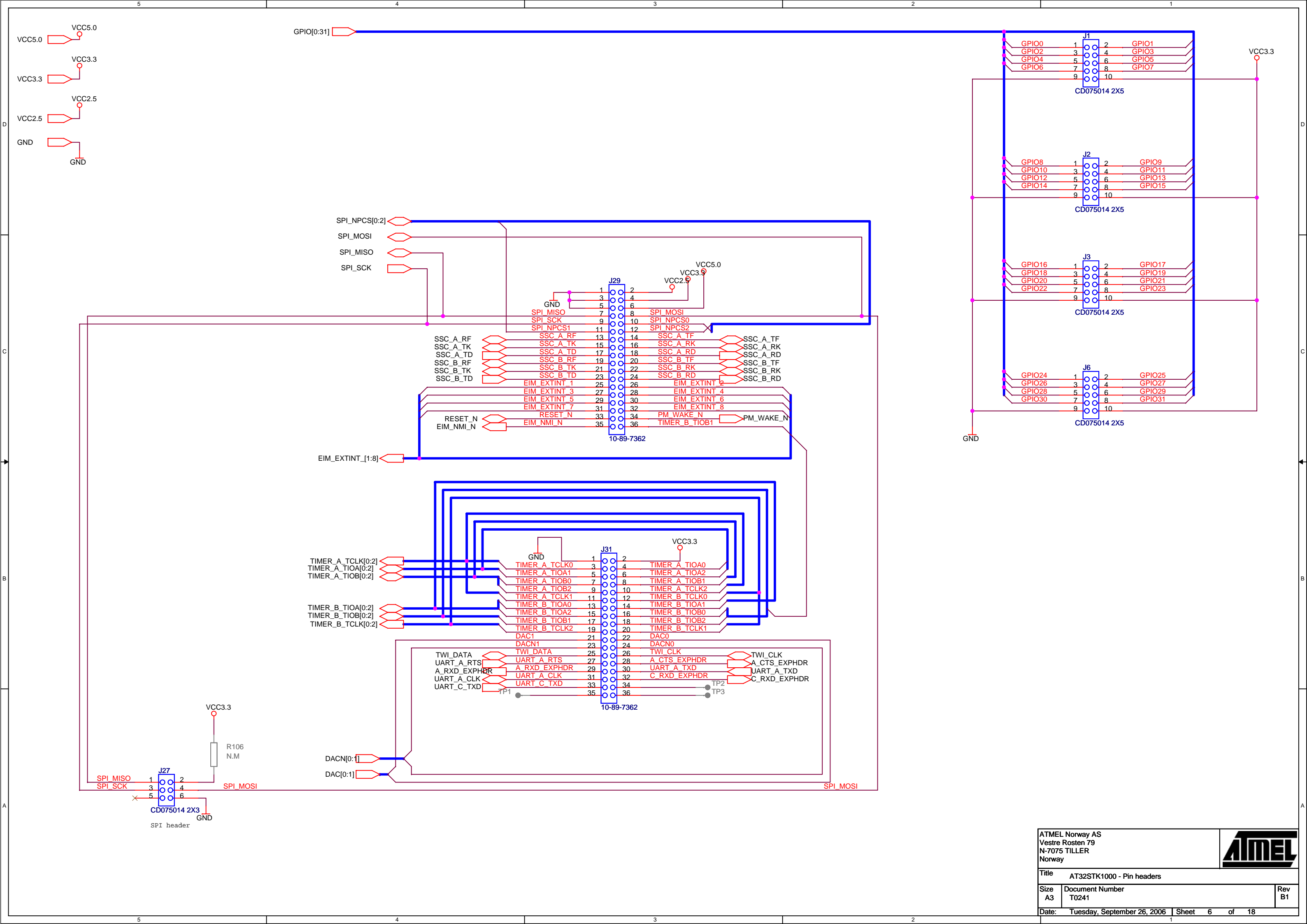



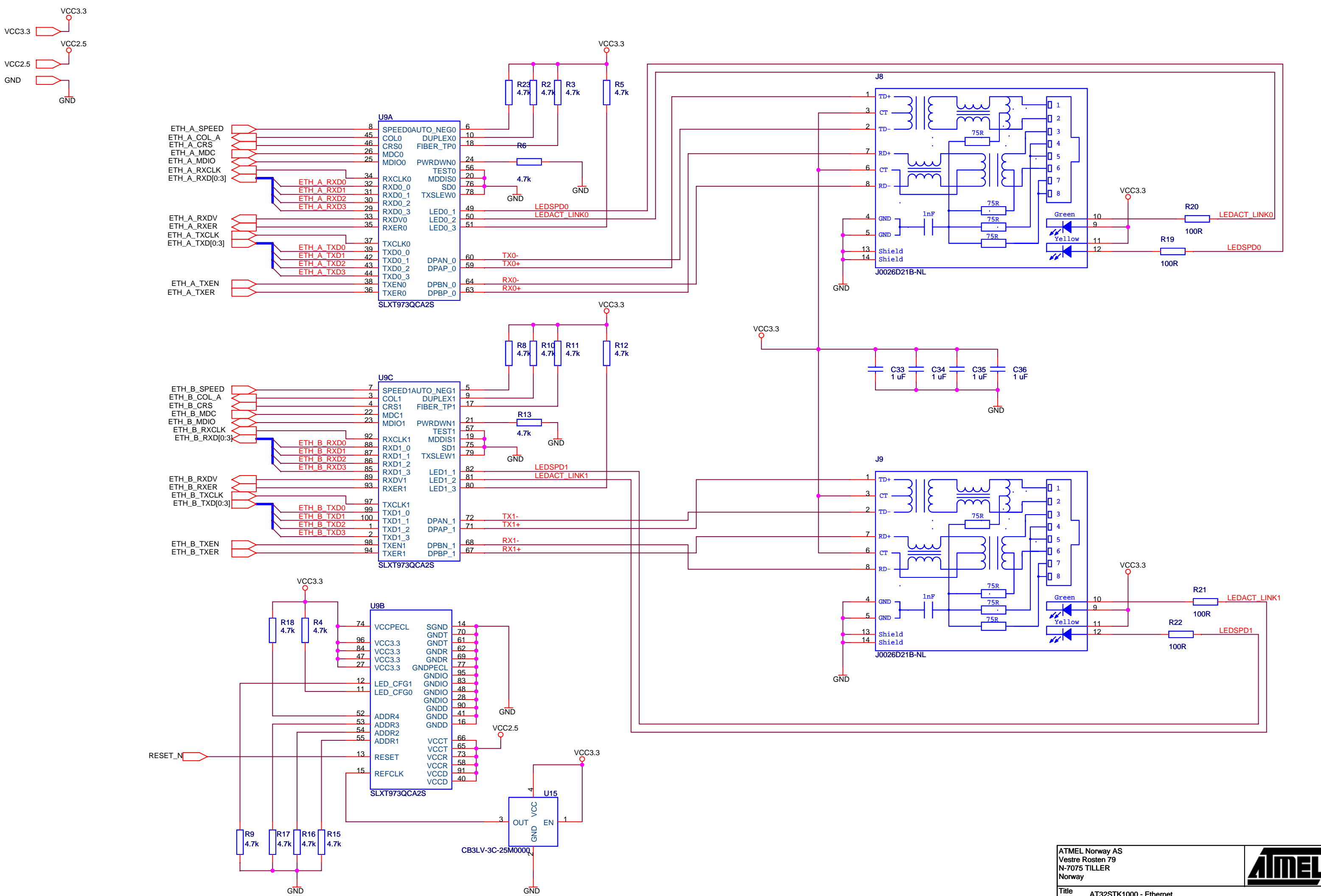

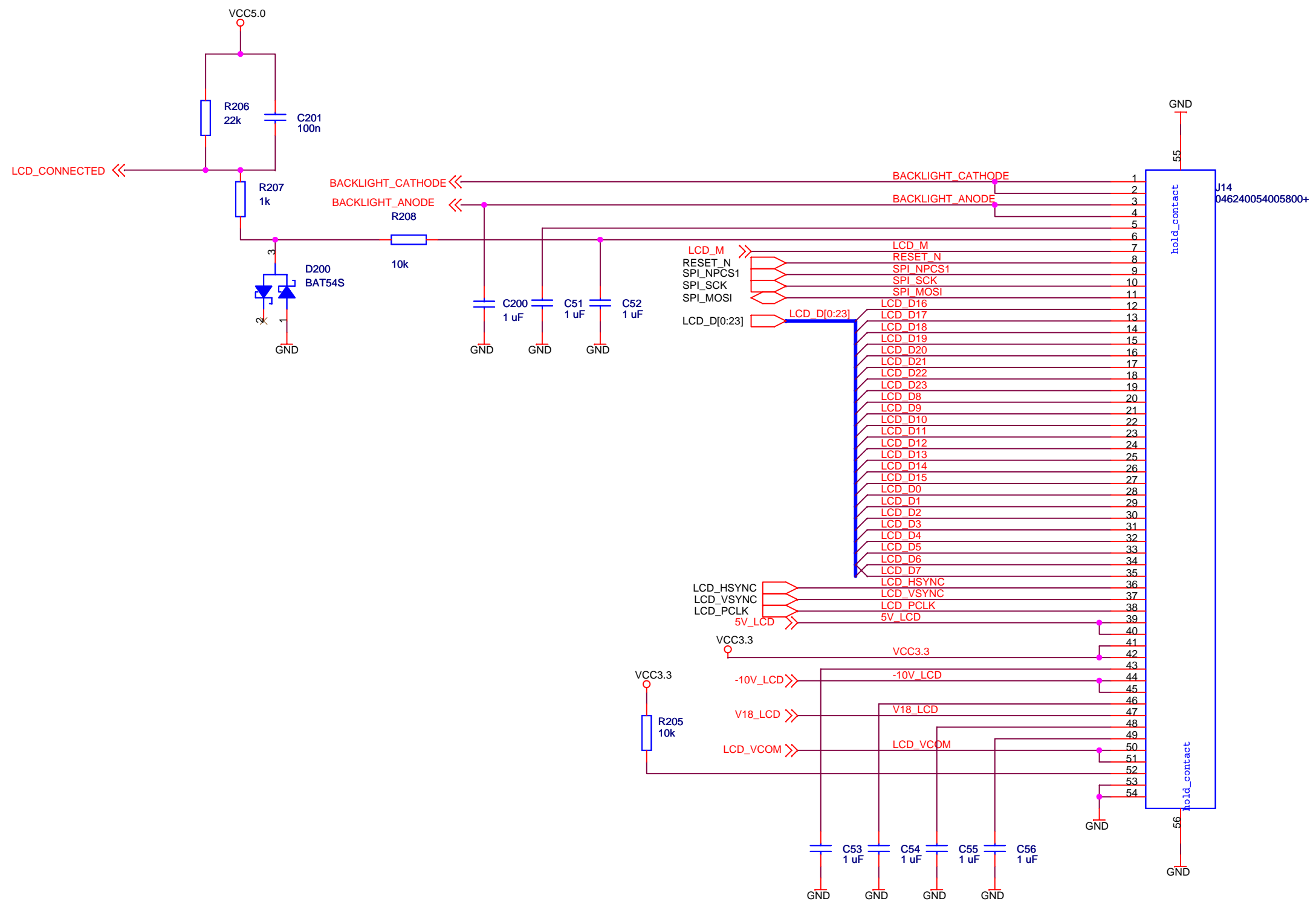
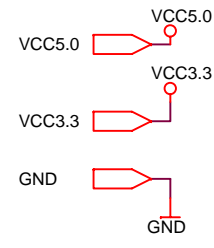



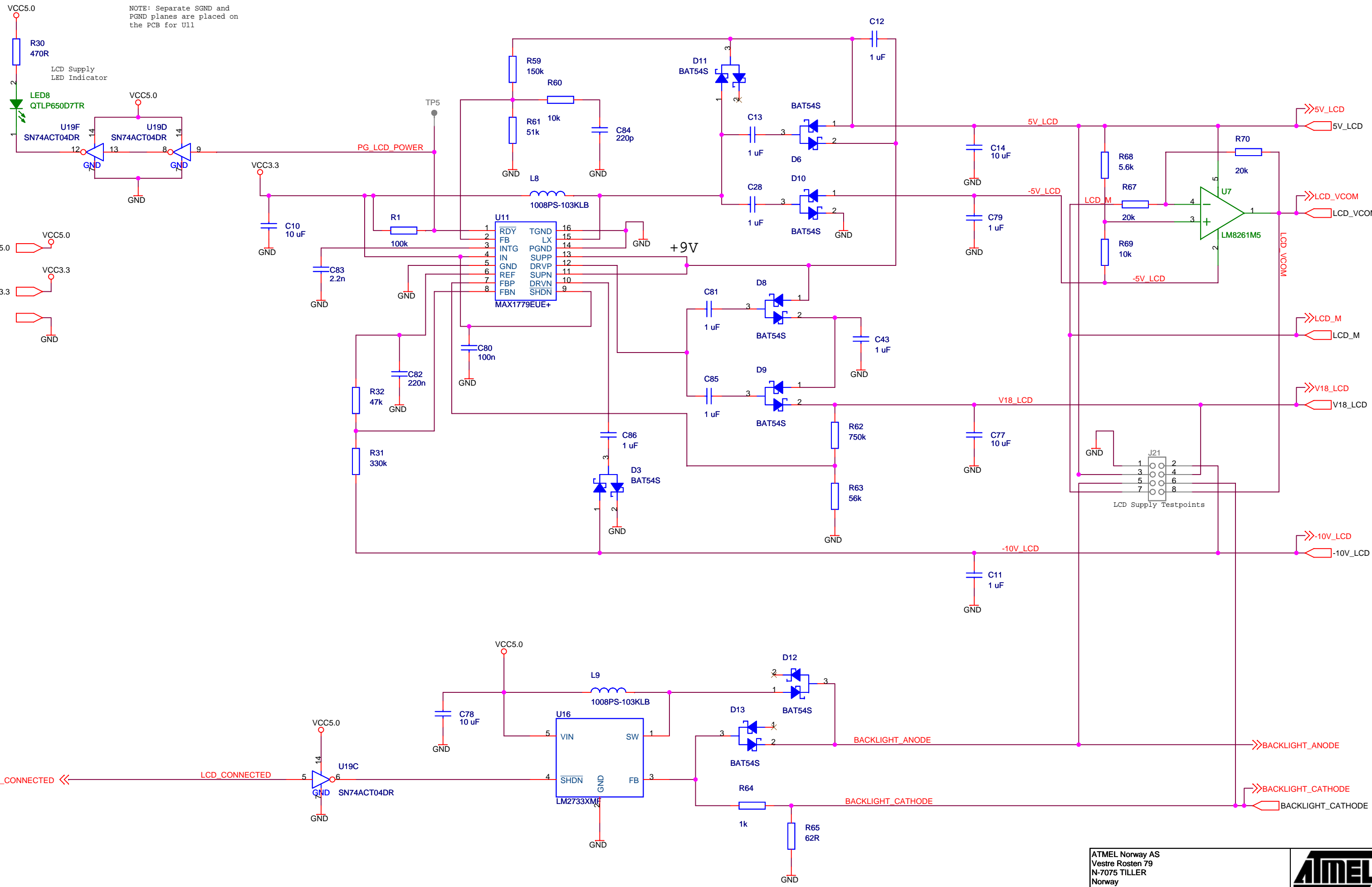

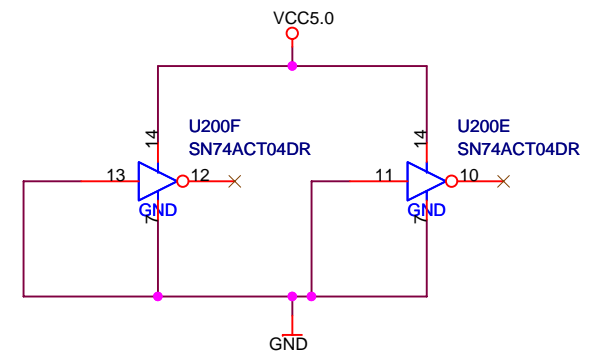
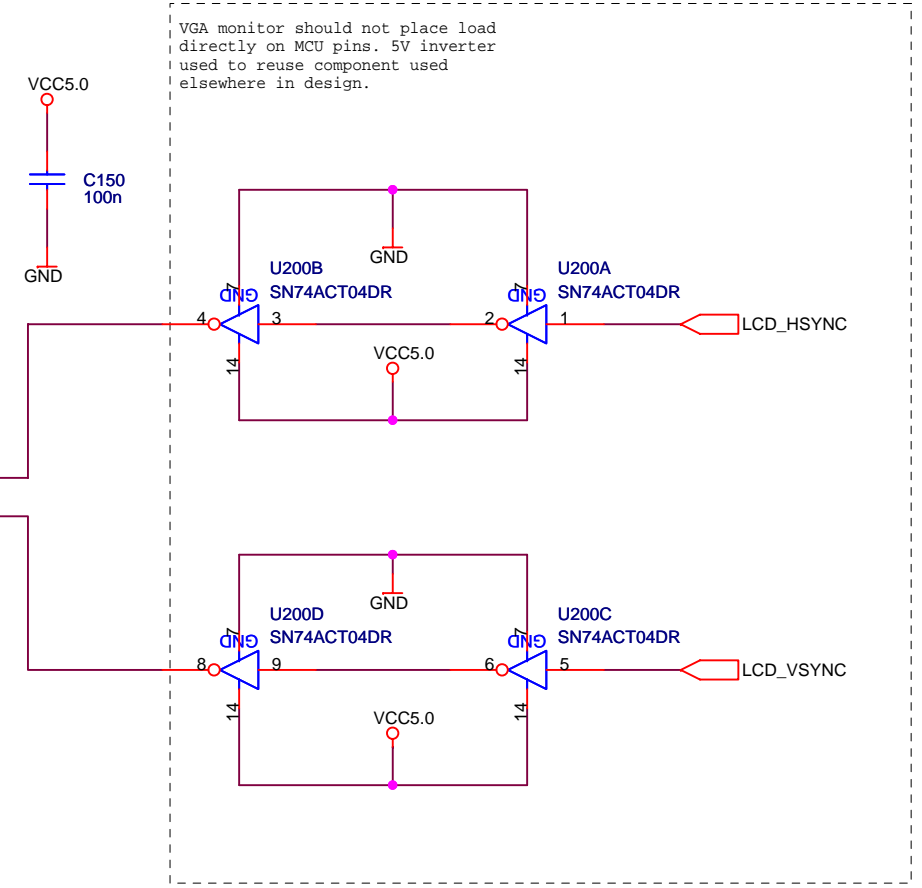
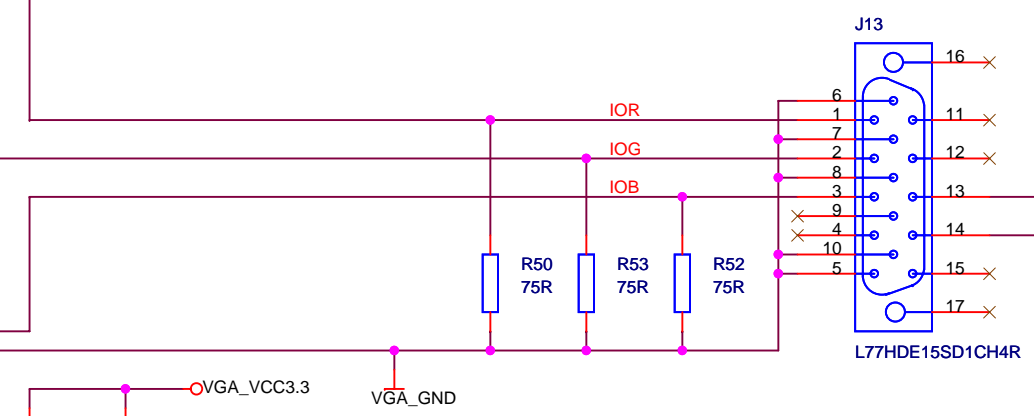
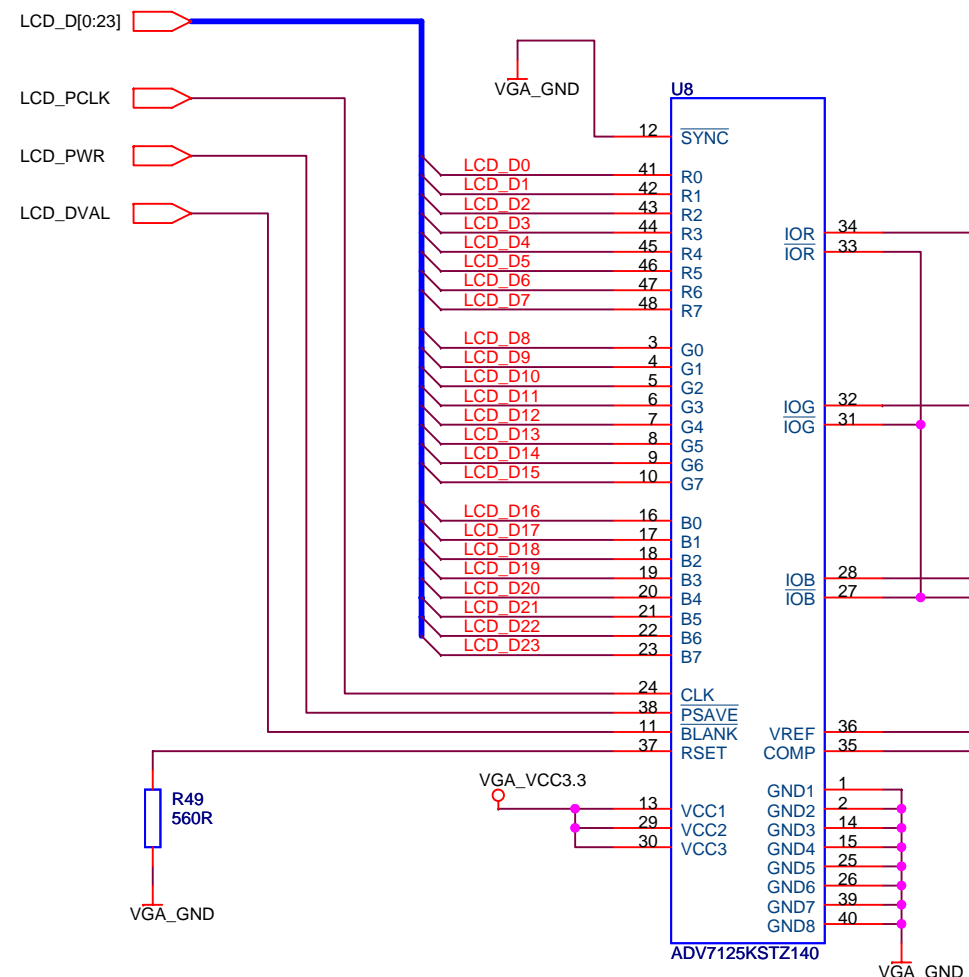
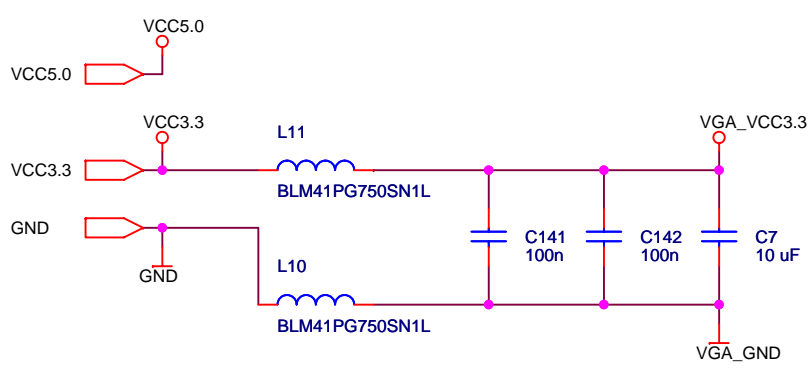

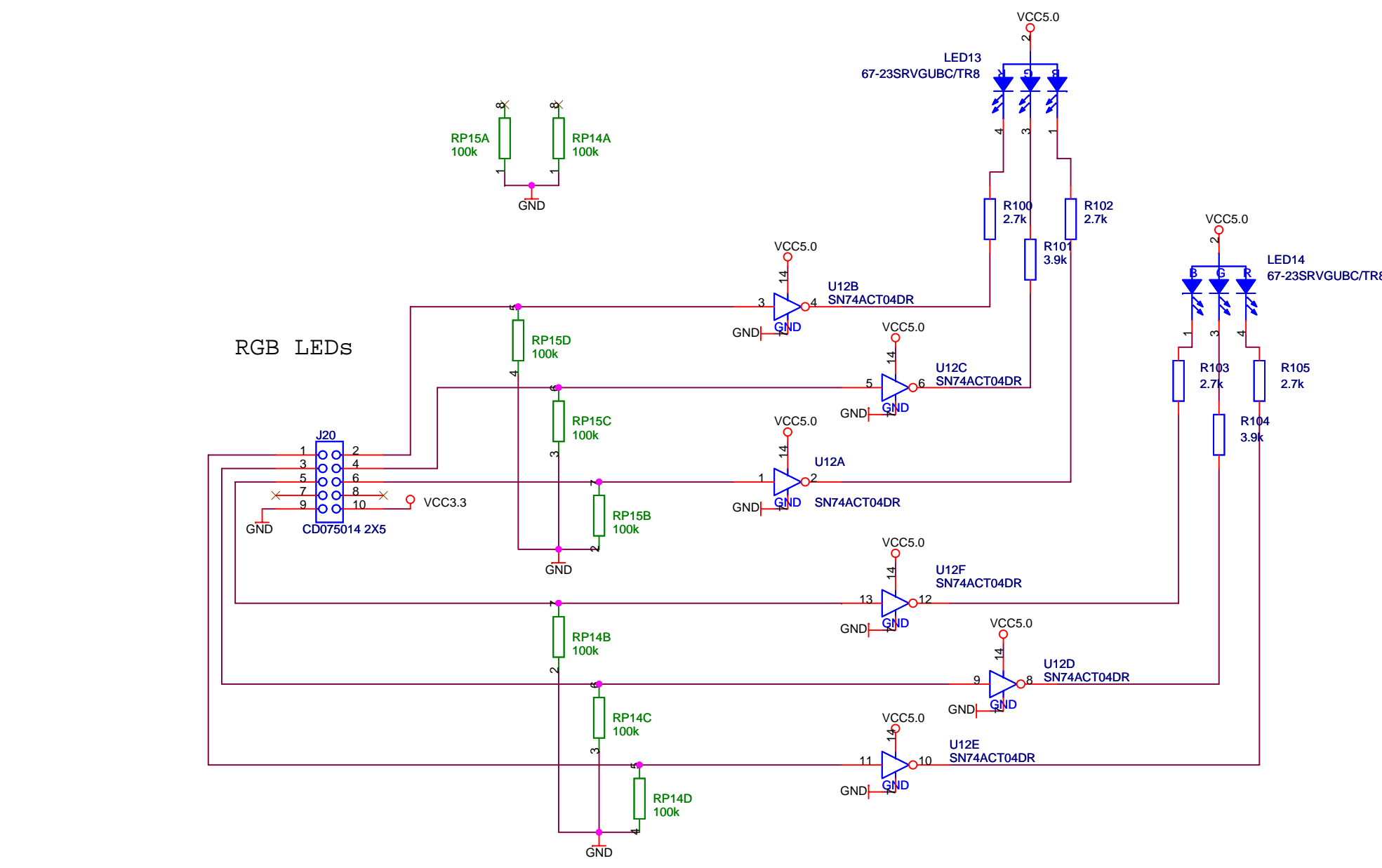
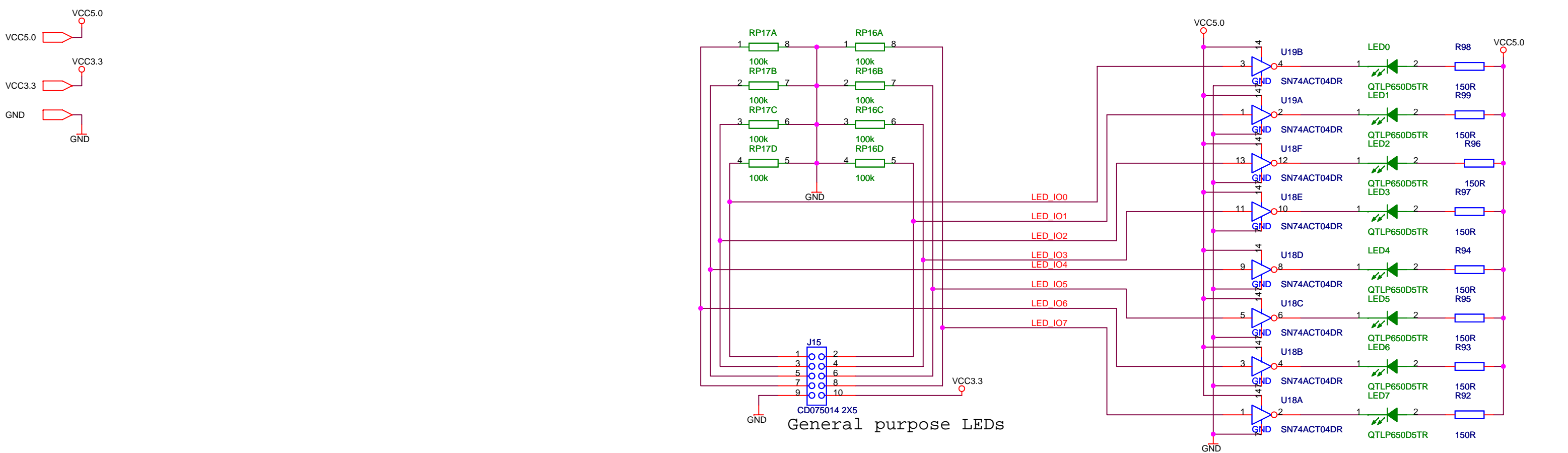

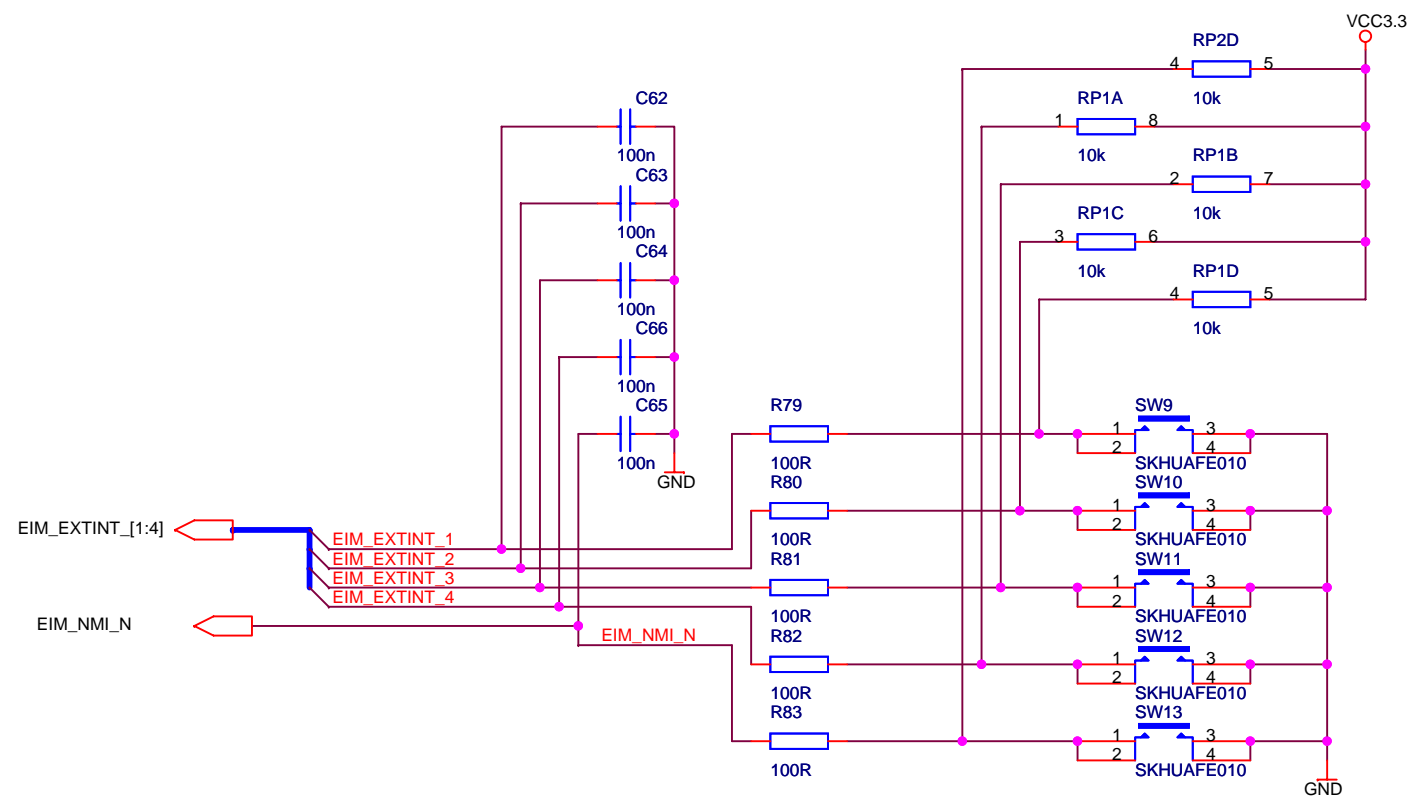

Interrupt switches

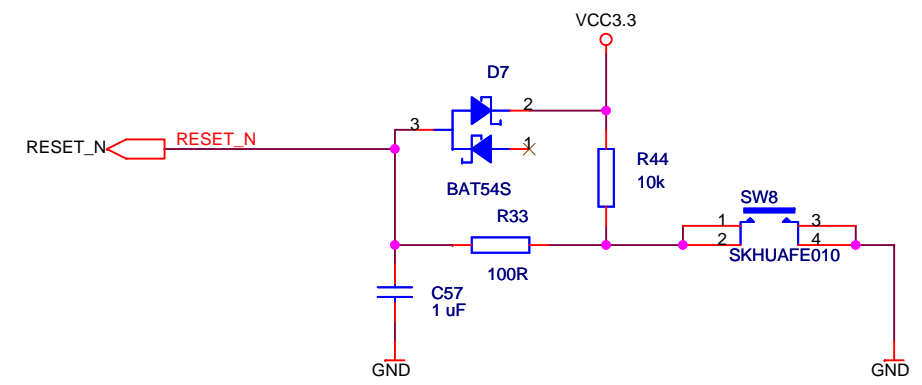

Reset switch

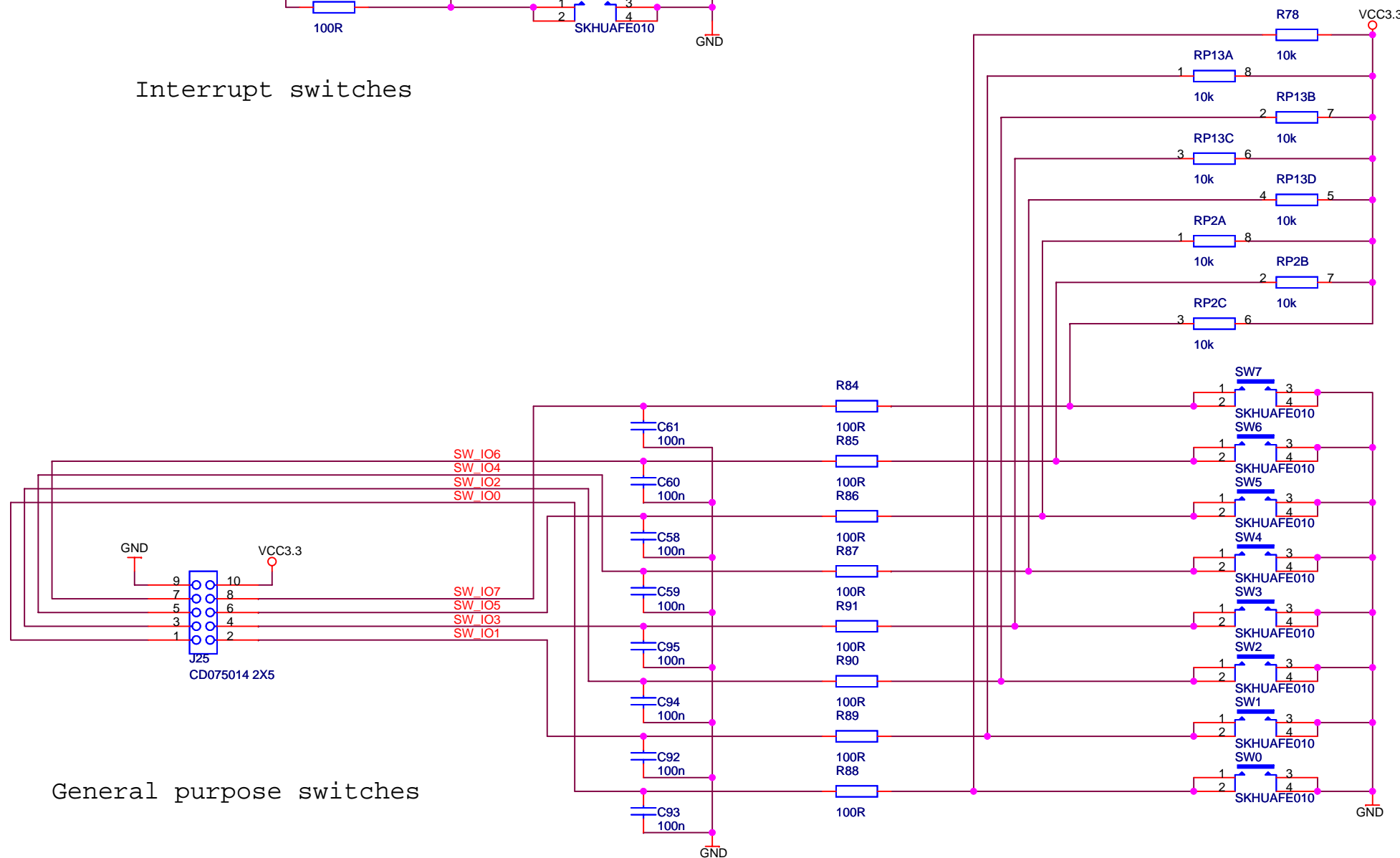

General purpose switches

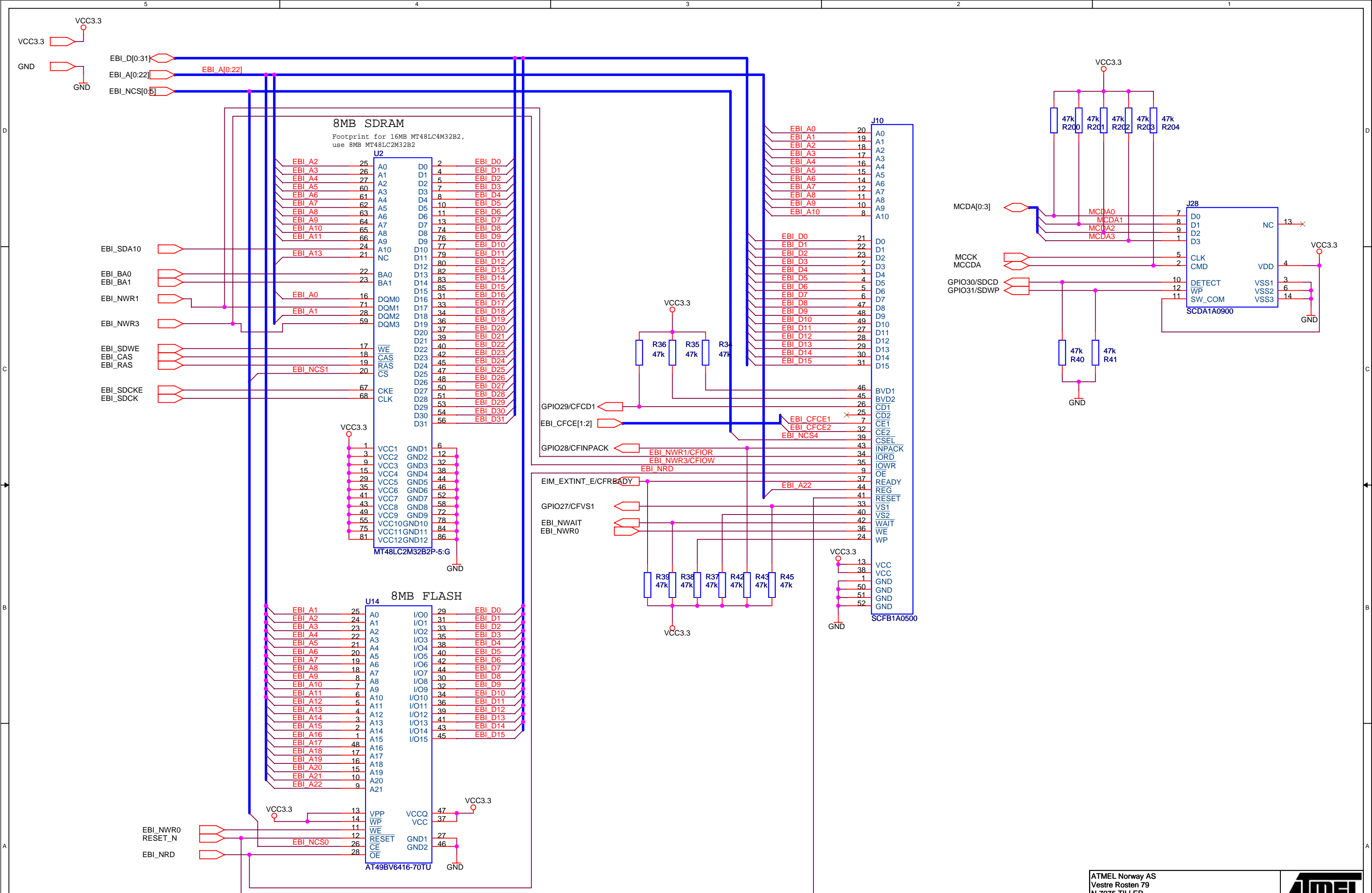

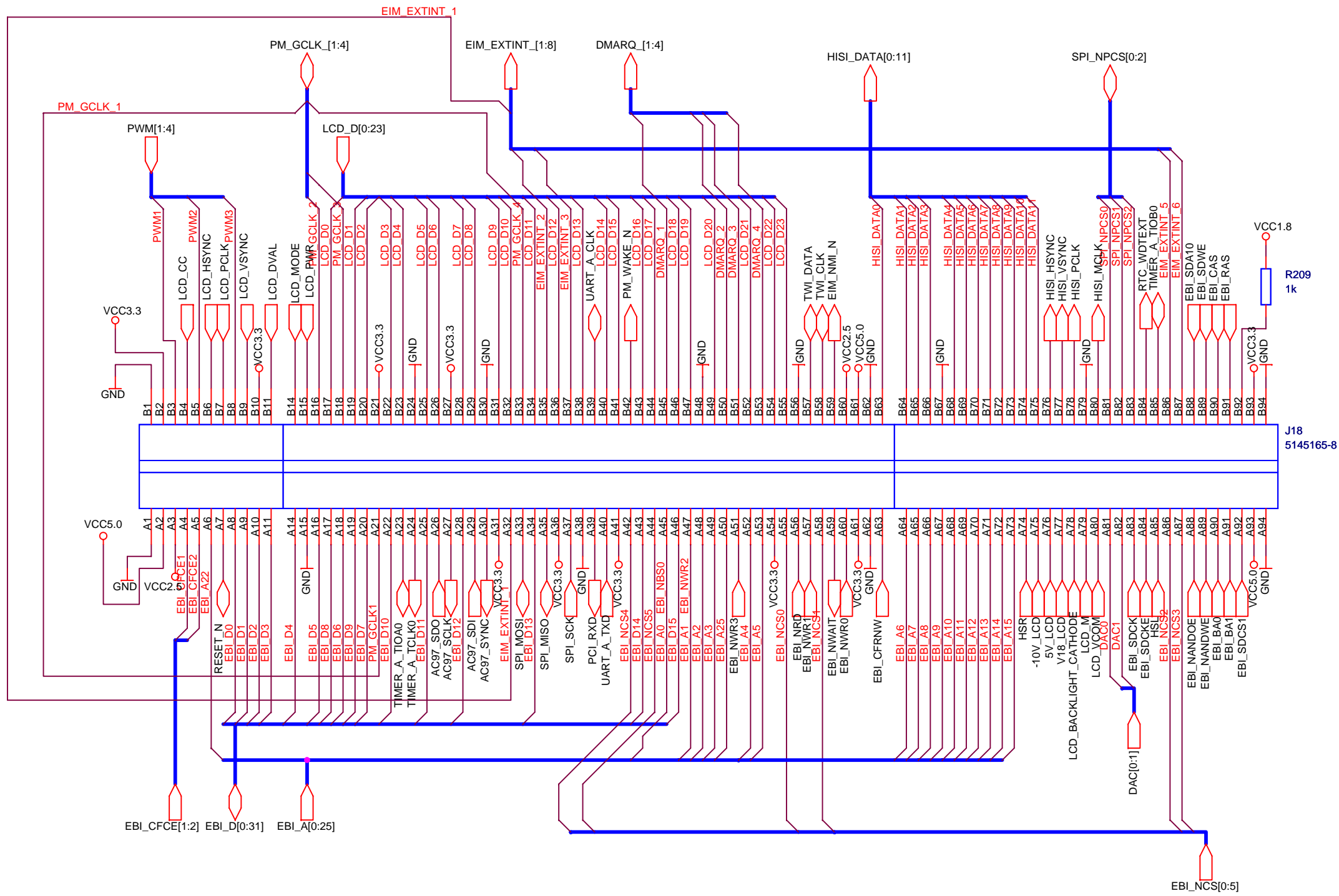
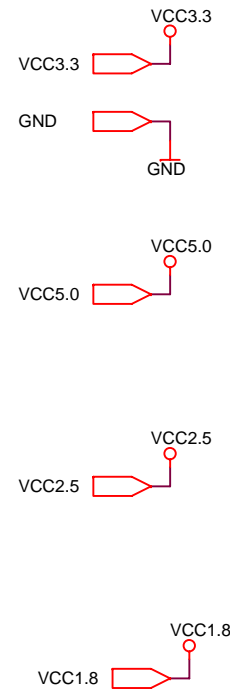

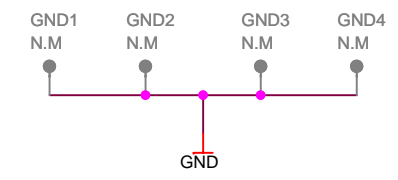
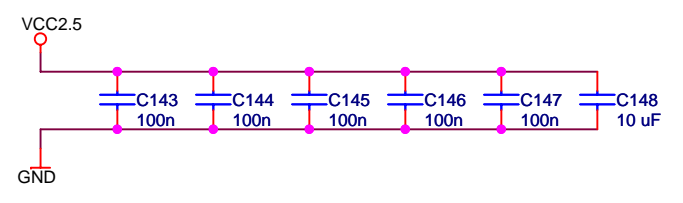
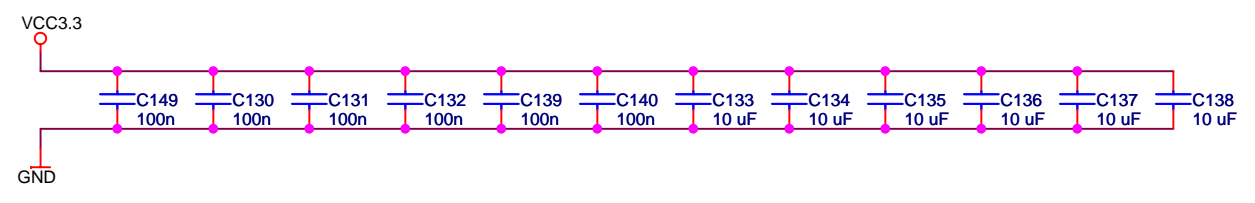
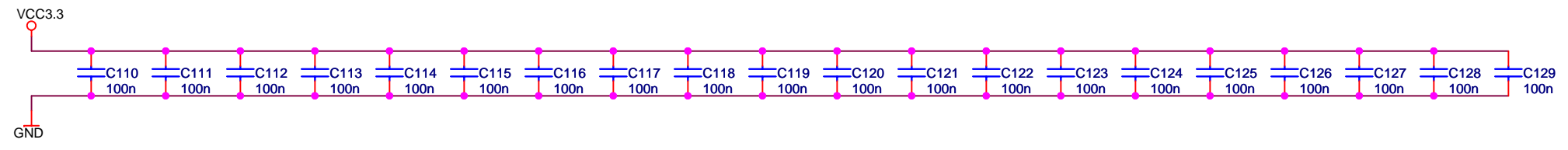
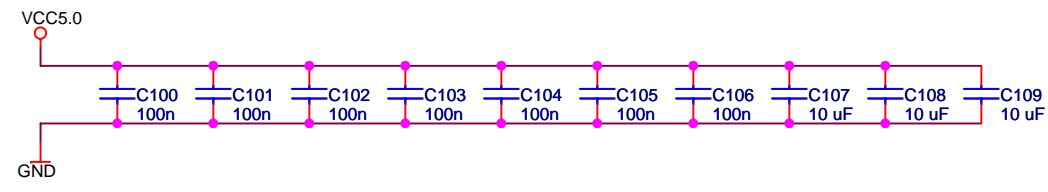
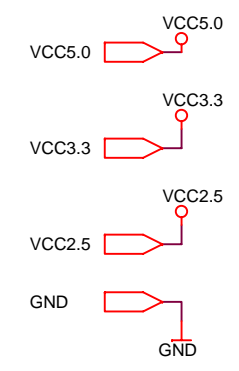



NOTE: Power on sequece is : 5V, followed by 3.3V, followed by 2.5V, followed by 1.8V

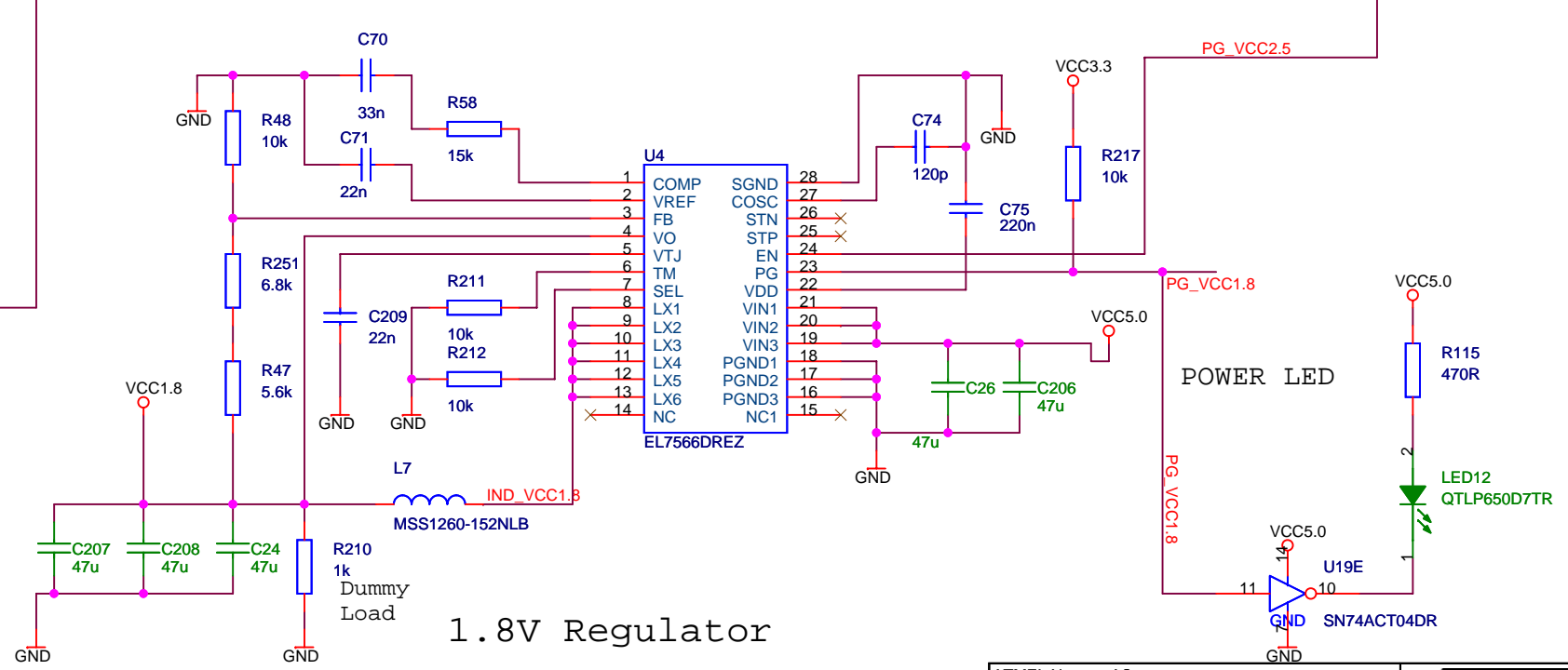
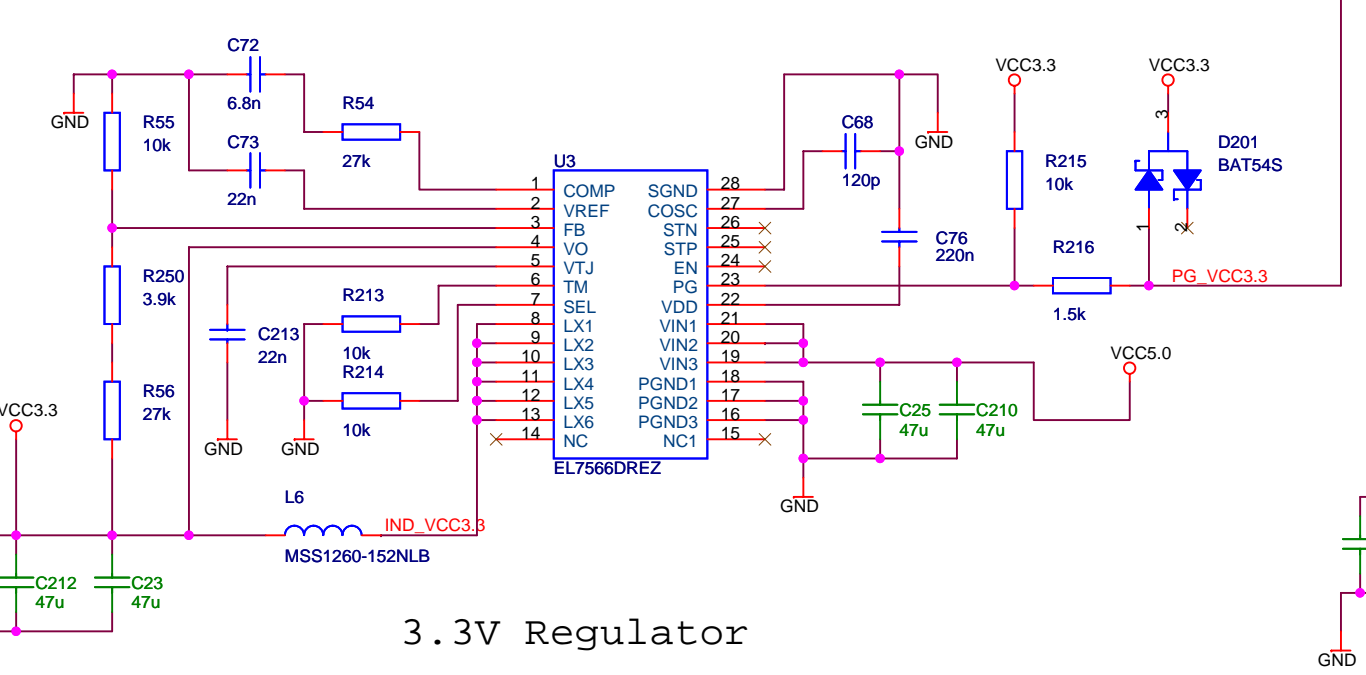
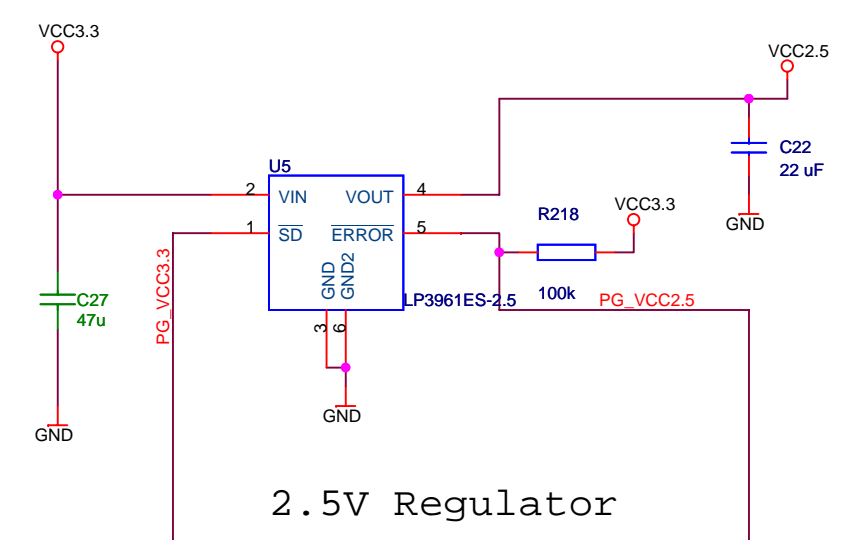
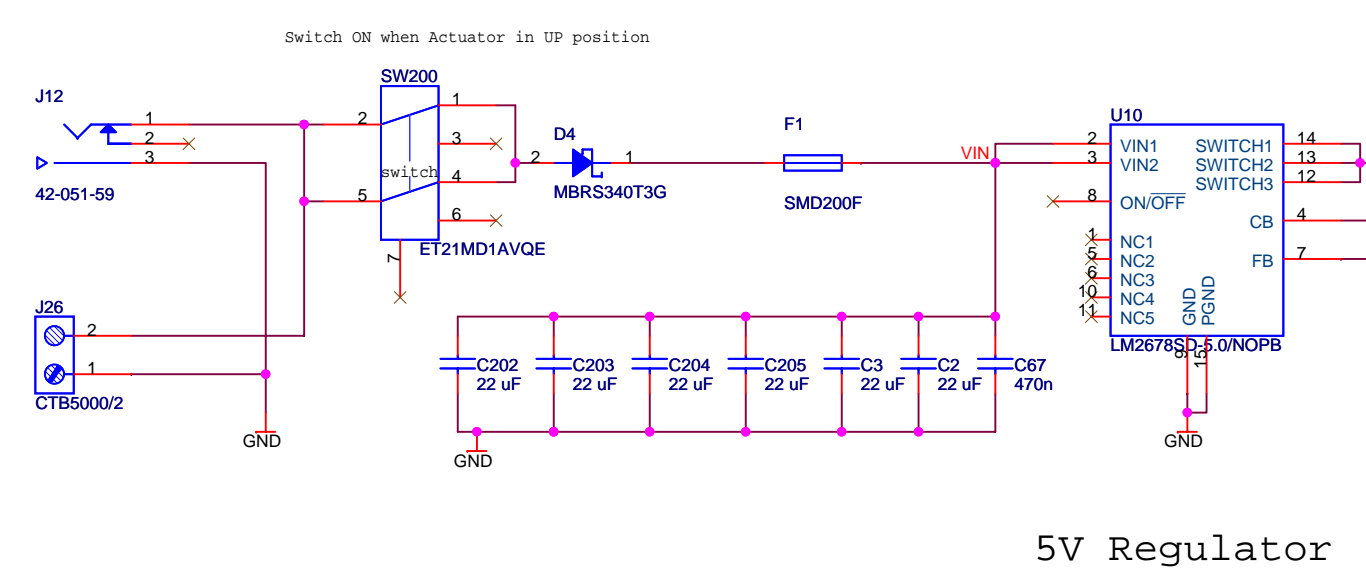
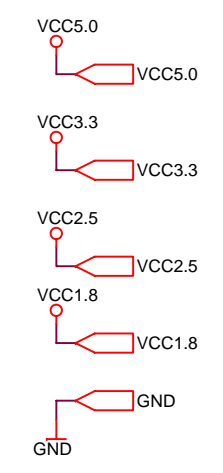
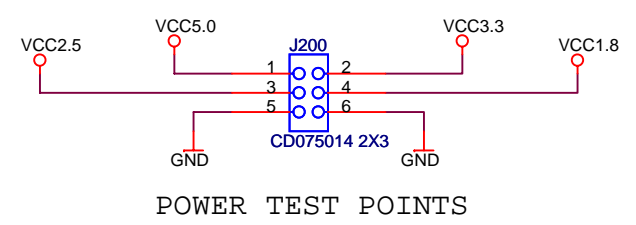

NOTE: Separate SGND and PGND planes are placed on the PCB for U3 and U4

ATMEL Norway AS Vestre Rosten 79 N-7075 TILLER Norway		
Title: AT32STK1000 - Power		
Size: A3	Document Number: T0241	Rev: B1
Date: Tuesday, September 26, 2006		Sheet: 16 of 18

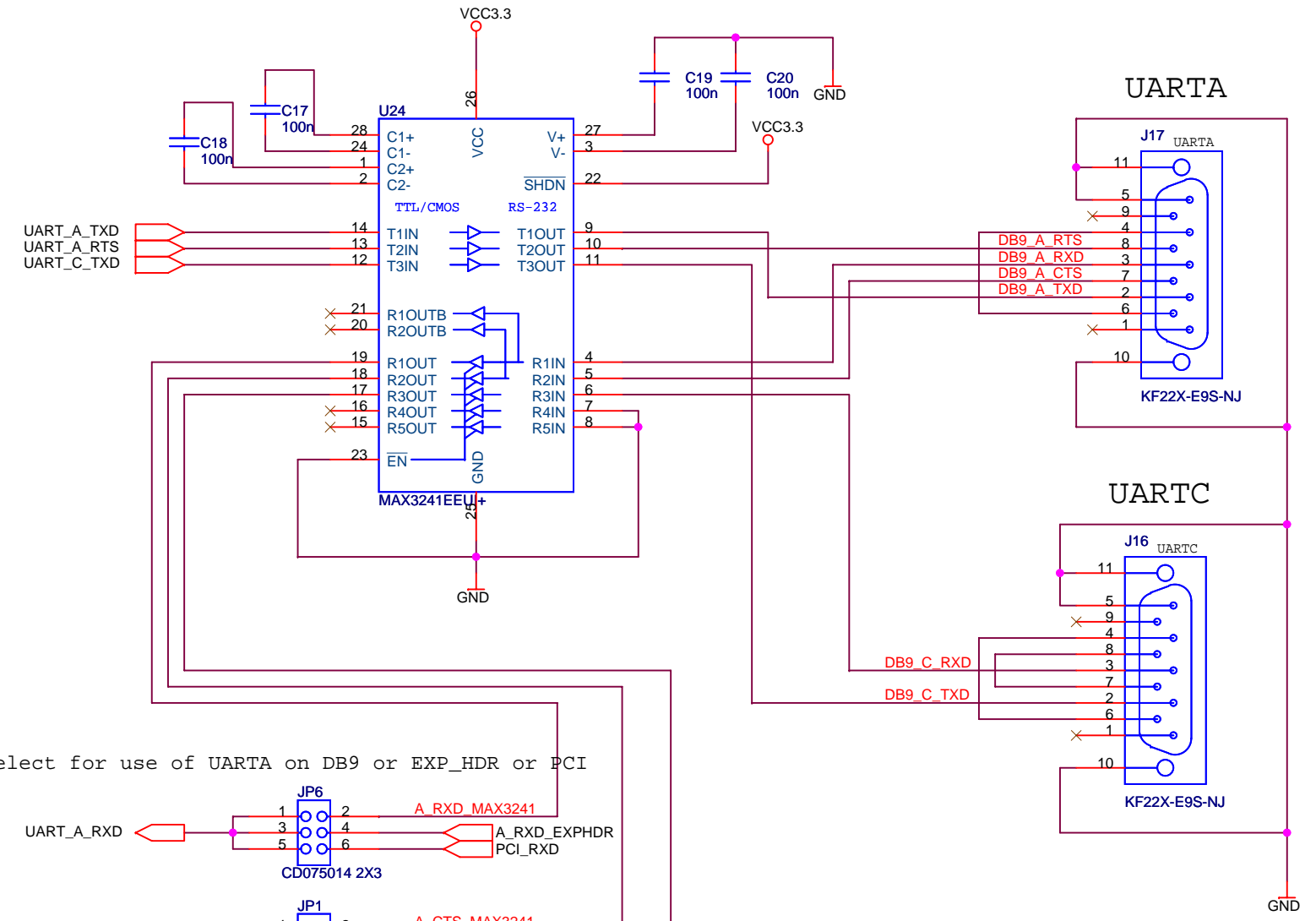
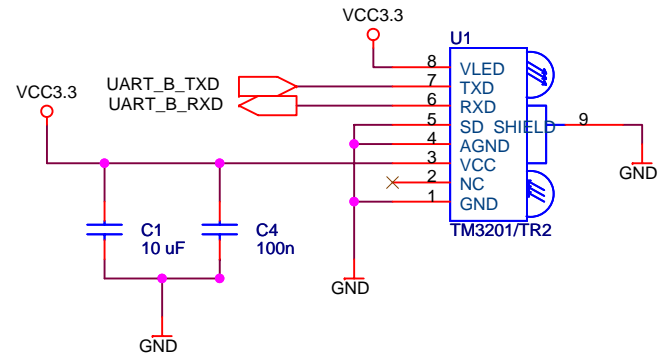
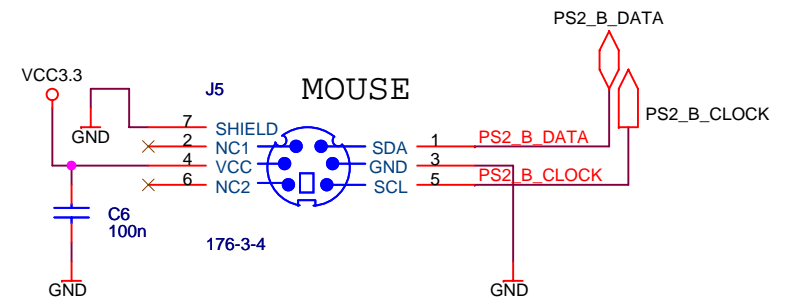
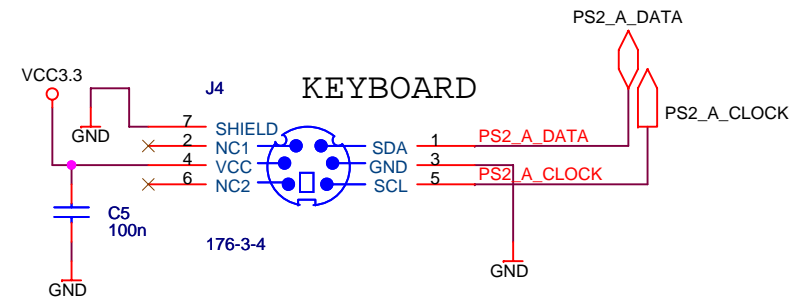
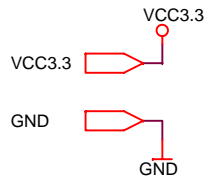

Jumper Select for use of UARTA on DB9 or EXP\_HDR or PCI

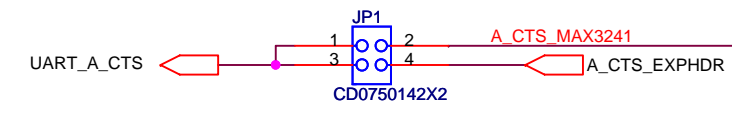
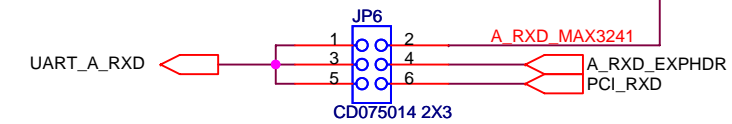

Jumper Select for use of UARTC on DB9 or EXP\_HDR

